

CONTENTS

INTRODUCTION / ABOUT REVAL STONE	3
SUSTAINABILITY	7
OUR PREMISES	8
REFERENCES	11
WALLS AND FACADES	36
QUALITIES OF DOLOMITE AND LIMESTONE MASONRY STONES	42
PANEL FACADES	44
FLOORS, STAIRCASES, SKIRTING BOARDS	56
SUSPENDED CEILINGS FROM NATURAL STONE PANELS	68
USES	70
OUR STONES: KAARMA, ORGITA, SELGASE & REVAL	75
FINISHES	80
SPLIT-FACE OUTSIDE	88
GALLERY	91

REVAL STONE

LIMESTONE FACTORIES OF ESTONIA



REVAL STONE

LIMESTONE FACTORIES OF ESTONIA

Reval Stone is the architectural natural stone brand of Limestone Factories of Estonia OÜ, one of the oldest natural stone miners and processors in Estonia. We produce and supply Baltic limestone and dolomite for facades, stairs, plazas, landscaping elements, interiors, and other architectural applications across Estonia, Latvia, Sweden, and nearby markets.

Our role is simple: to take a noble regional material and make it precise, reliable, and relevant for contemporary architecture.

A Material with Deep Roots

Limestone is the national stone of Estonia, and its use in local architecture goes back more than 700 years. Saaremaa dolomite has been used since the 13th century in castle walls, churches, and other enduring structures that remain part of the region's architectural identity to this day.

This heritage is not only historical. It is proof. Baltic limestone and dolomite have already demonstrated their ability to carry time, climate, and human use with quiet strength and dignity.

Reval Stone exists to continue that story by bringing this proven material into the hands of those shaping what comes next.

From Heritage to Contemporary Architecture

Imagine walking through an old town just before dusk. Stone under your feet, facades catching the last light, stairs worn smooth by thousands of footsteps. You do not think about it, but the material holds the whole scene together. It feels grounded, calm, and lasting.

That is the world our stone comes from.

Working from our quarries and factory in Estonia, we turn Baltic limestone and dolomite into future heritage — facades, plazas, plinths, stairs, landscaping elements, and interiors that will still feel right in 20, 30, or 50 years. The stone is noble by origin; our role is to make it usable for today's design, construction, and performance expectations.

Behind the Reval Stone brand stands Limestone Factories of Estonia OÜ. The company was formed in 2022 through the merger of Saare Dolomiit-Väokivi and Paekivitoodete Tehase OÜ. One of its predecessor companies, Saare Dolomiit-Väokivi, traces its industrial roots back to October 1, 1967, when the Saaremaa plant of Eesti Dolomiit was established. Since 2007, the company has used the Reval Stone brand to market its natural stone products.

Today, we combine long-term stone expertise with modern production capabilities and a clear Baltic-Nordic market focus.

our materials

What We Offer

We offer a wide range of natural stone products and project solutions for contemporary architecture and construction.

Our applications include facades, stairs, plinths, flooring, wall surfaces, landscaping elements, public space solutions, windowsills, countertops, and custom project-based stone elements.

Alongside project-based supply, selected products are also available through our online shop, which we opened in 2021 to make Estonian limestone and dolomite more accessible to a wider audience.

Why Our Material

Baltic limestone and dolomite offer something increasingly valuable in architecture: authenticity, durability, and timeless relevance.

They bring together regional origin, long lifecycle, low maintenance needs, and a material language that feels both grounded and quietly premium. They suit historic surroundings, modern buildings, public space, and contemporary Nordic architecture alike.

This is not a material chosen for short-term effect. It is chosen for places meant to last.

our clients

Who We Serve

We work with architects, interior designers, developers, city builders, contractors, and project partners who want more than a finishing material. They want a solution with architectural credibility, practical reliability, and long-term value.

Our role is to help each of these stakeholders work with natural stone in a way that is both ambitious and realistic — whether the goal is a refined façade, a durable public space, or a custom project element that must meet both technical and aesthetic expectations.

What Clients Gain

Choosing Reval Stone means choosing more than a supplier. It means choosing a partner who understands both the heritage of the material and the realities of contemporary projects.

For architects, this means design freedom supported by technical clarity. We provide clear data, realistic formats and finishes, and honest feedback on what can be achieved, so the architectural vision can be translated into stone with confidence.

For developers and city builders, this means long-term value. Baltic limestone and dolomite support sustainability narratives through regional origin and sensible transport distances, while also offering durability, low maintenance, and a timeless appearance that continues to add value years after completion.

For contractors and partners, this means smoother cooperation. We offer standard solutions where efficiency matters, tailored solutions where design requires flexibility, and a working relationship focused on reducing uncertainty and supporting reliable execution.

What clients gain is simple: confidence, clarity, and a result that still feels right decades later.

our markets

One Region, Three Perspectives

We think in terms of one region and three strategic perspectives.

Estonia is home — the proof market where limestone and dolomite already live in museums, civic buildings, promenades, and contemporary architecture.

Latvia is a natural bridge — a market where Baltic stone works especially well in historic urban fabric, hospitality, and premium residential development.

Sweden is where this logic scales further — a market that values design quality, lifecycle thinking, sustainability, and durable material choices within the Nordic architectural palette.

Our Vision

Our vision is to become the leading manufacturer and seller of finishing materials made of Estonian limestone and dolomite in the Baltic States and Scandinavia, with 70–80% of our production exported to nearby foreign markets.

At the same time, our mission remains rooted in something deeper: to continue the long tradition of Estonian limestone and dolomite and introduce its value to a wider audience through architecture, design, and construction.

At the heart of Reval Stone is a simple belief: some materials are meant to do more than fill a specification line. A noble stone with real history, used with clarity and intention, can quietly support the life of a city for generations.

When someone in the future walks across a square, touches a facade, or climbs a stair made from our stone, we want it to feel like it has always belonged there.

Because together, we are not just creating today's finish.
We are creating tomorrow's heritage.

sustainability

Sustainability in Stone

For us, sustainability begins with the material itself.

We work with Estonian limestone and dolomite because they are natural, durable, and deeply rooted in this region. These stones have already proven their value over centuries in architecture and public space. Saaremaa dolomite has been used since the 13th century, and Reval limestone has long been part of historic urban construction. That longevity matters: a material that lasts for generations reduces the need for replacement and helps buildings age with dignity.

We also believe sustainability is about place. Our stone comes from our quarries in Saaremaa, Tallinn, and Märjamaa, and is processed in Estonia. This gives our clients a material with authentic regional origin and a more grounded supply story than many imported alternatives.

Sustainability is also about how the material is used. We continue to improve resource efficiency and responsible production. According to our company information, after production upgrades, 92% of mined limestone is transformed into washed sand and crushed stone, while the remaining material is further processed into usable raw materials. Since 2023, our company has also held the Green Choice certificate confirming the use of 100% European-produced renewable energy.

For us, the strongest sustainability argument remains simple: natural stone is made to last. It offers durability, low maintenance, weather resistance, and a timeless appearance that remains relevant long after trends have passed.

Because the most sustainable surface is often the one you do not need to replace.



our premises



Quarry (Reval, Orgita, Kaarma, Selgase)



Factory (Tallinn, Kaarma)

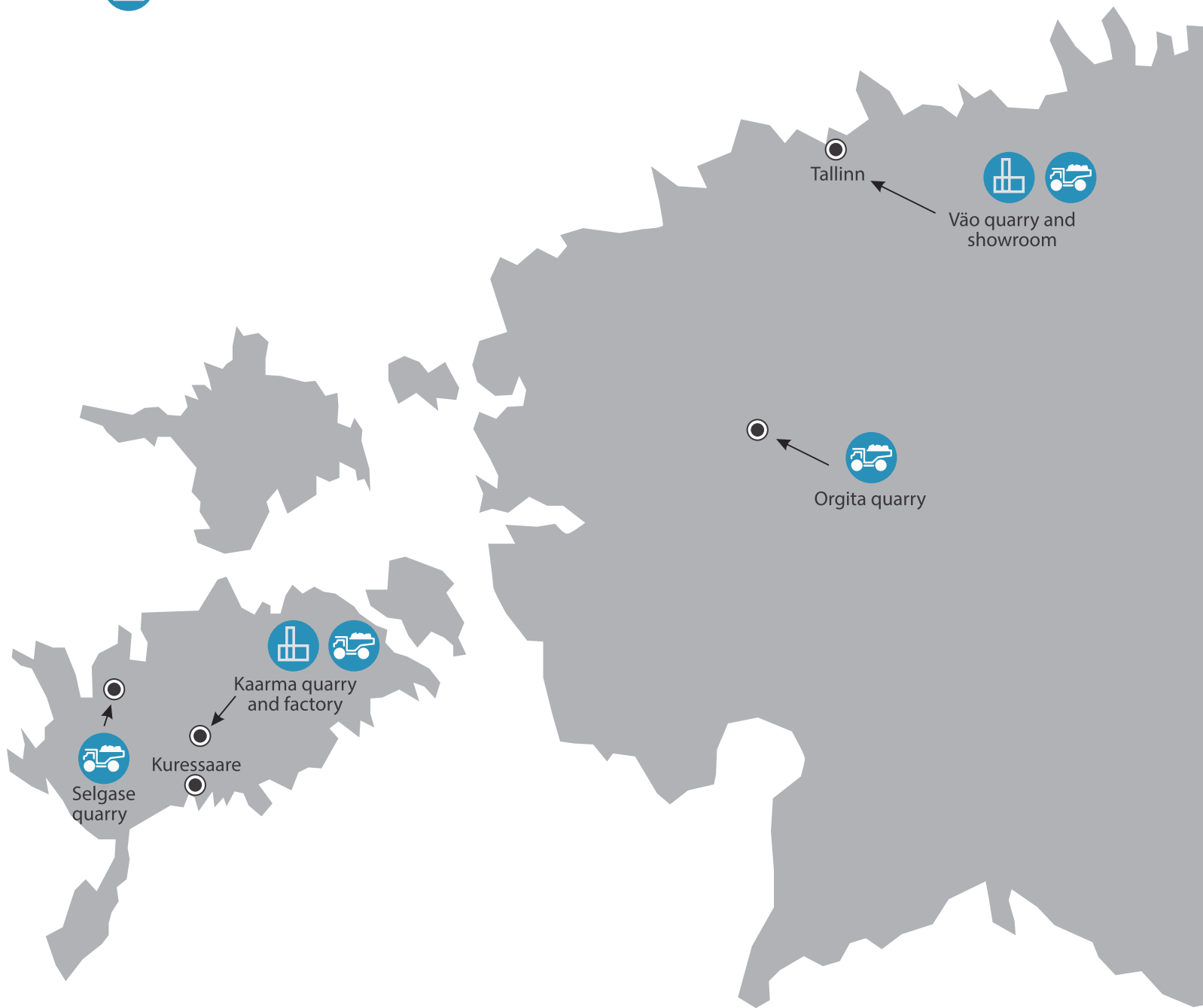

REVAL STONE

LIMESTONE FACTORIES OF ESTONIA



Our quarry



Reval Stone factory in Kaarma, Saaremaa, Estonia

The background is a dark grey, almost black, surface with a fine, granular texture, resembling diamond honed metal. A single vertical white line runs down the center of the page, passing through the text.

References in ESTONIA

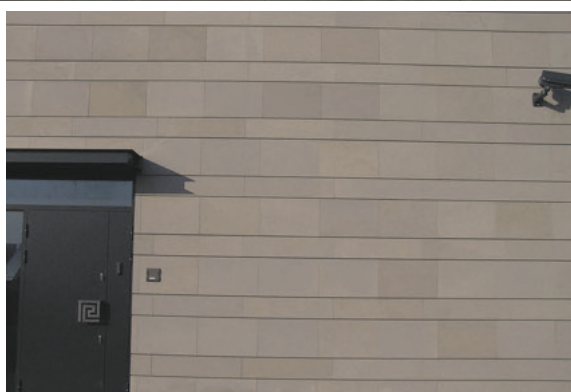
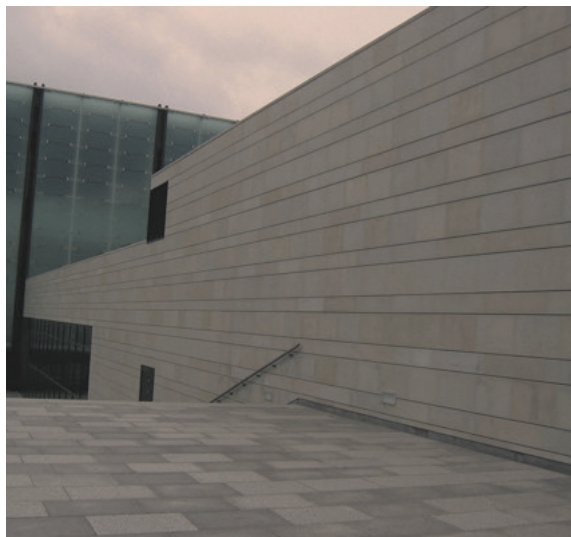

KUMU ART MUSEUM
dolomite facade, limestone floors and other
natural stone works (total area of 10 000 m²).
Weizenbergi tn, Tallinn.



**NOBLESSNER
RESIDENTIAL AREA**
Reval limestone facades



**REVAL
STONE**

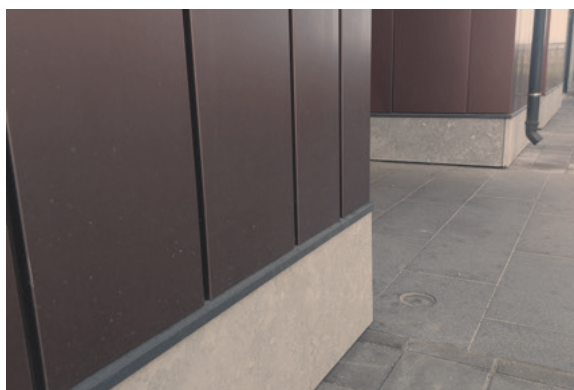

**NOBLESSNER
RESIDENTIAL AREA**
Kaarma dolomite

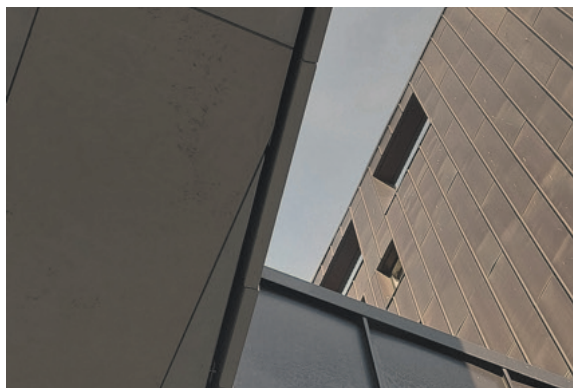
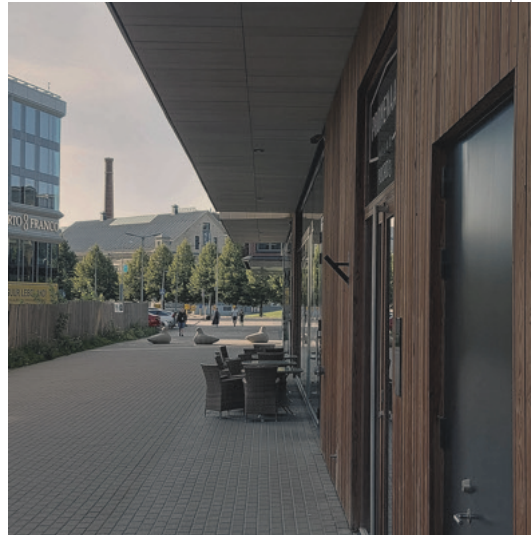

**NOBLESSNER
RESIDENTIAL AREA (Poordi 3)**

Orgita dolomite facade

more references in Estonia

- **Main building of Tallinn University:** Kaarma dolomite facade (700 m²). Narva mnt, Tallinn.
- **Hotel Europa in Tallinn:** Orgita dolomite facade (2000 m²). Paadi tn, Tallinn.
- **Estonia Theatre memorial sculpture in Tallinn:** natural stone works.
- **Estonian Academy of Music** – Orgita dolomite cornices (2400 m), chopped details, stairs, and floors. Rävälä pst 16, Tallinn.
- **Ministry of Foreign Affairs of the Republic of Estonia:** Orgita dolomite facade (2000 m²). Islandi väljak 1, Tallinn.
- **National Library in Tallinn:** dolomite facade with the area of 5000 m².
- **Grand Embassy of the Czech Republic in Tallinn:** dolomite facade and perimeter fence.
- **Haapsalu Culture Centre:** dolomite facade with the area of 2500 m².
- **Expansion wing of the Presidential palace of the Republic of Estonia:** dolomite exterior finishing together with the balustrade.
- **Kadrioru Palace in Kadrioru, Tallinn:** dolomite balcony perimeter/balustrade.
- **Solaris Shopping Centre:** Selgase dolomite facade (4500 m²). Estonia pst, Tallinn.
- **Tallinn Synagogue:** Reval limestone floors. Karu tn, Tallinn.
- **Jaani church in Viljandi, Jaani Church in Tartu, Valga Church:** altar stairs and altar table.
- **Kuressaare Airport:** dolomite facade.
- **Culture centre in Kuressaare:** dolomite facade.
- **Shopping centre in Kuressaare:** dolomite facade.
- **"Audi" dealerships in Kuressaare and Pärnu:** dolomite facades.
- **Hotel Johan:** Kaarma dolomite facade. Kauba tn, Kuressaare.
- **Spa "Tervise Paradiis" in Pärnu:** dolomite floor.
- **Convent of Saint Brigitte in Tallinn:** dolomite floors, interior walls, stairs, altar, and perimeter fence posts.



References in SWEDEN

Kaarma diamond honed

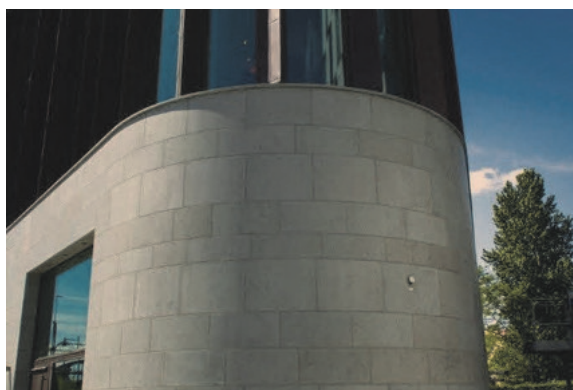
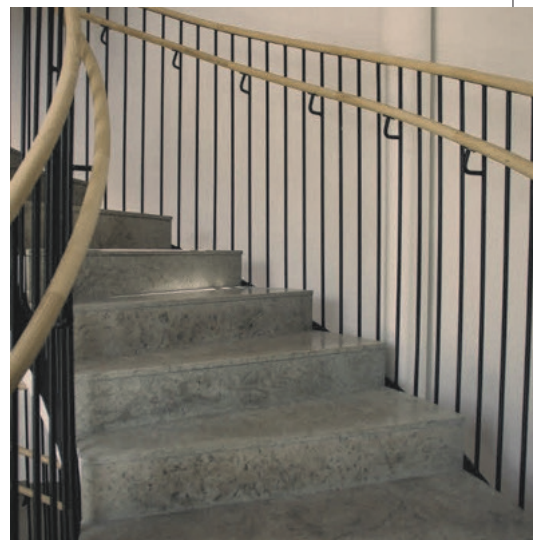

COURT OF APPEAL BUILDING IN LUND

Orgita dolomite facade, stairs, internal floors, window sills

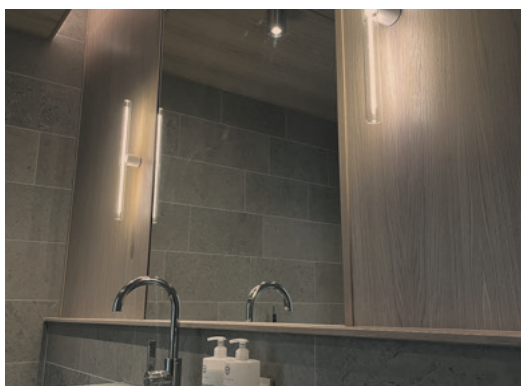
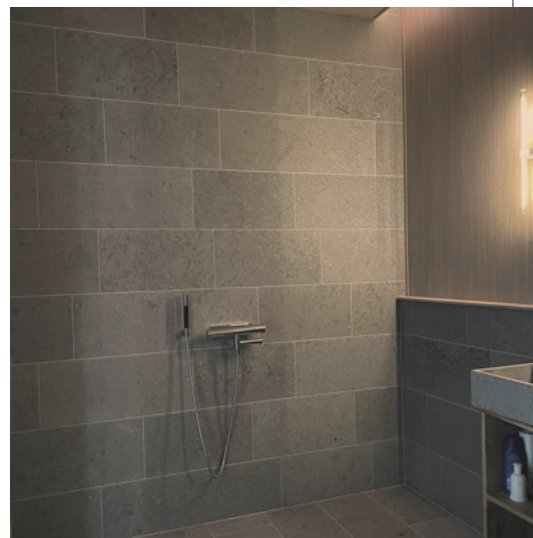

GUSTAV FREDRIKSSON

Reval limestone



**REVAL
STONE**



VILLA ÅRASLÖV

Reval limestone



**REVAL
STONE**



VILLA ENSKEDEDALEN
Countertops, kitchen island Reval limestone



**REVAL
STONE**

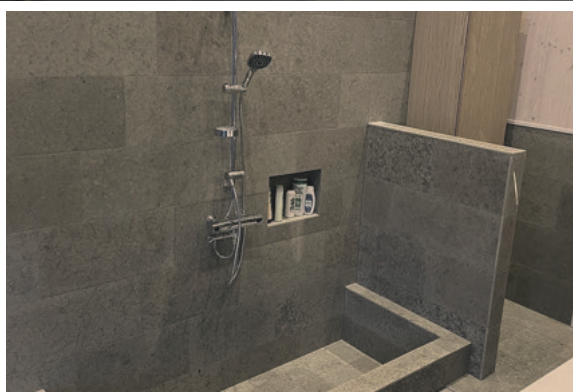

DALEKE
Reval limestone

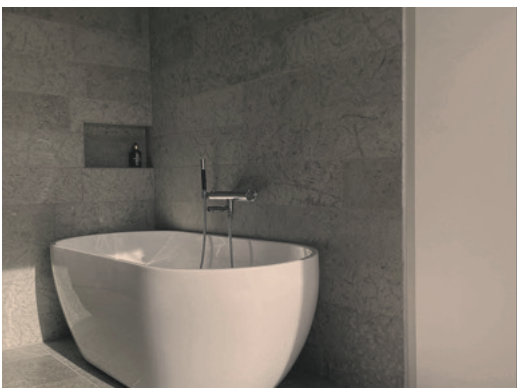
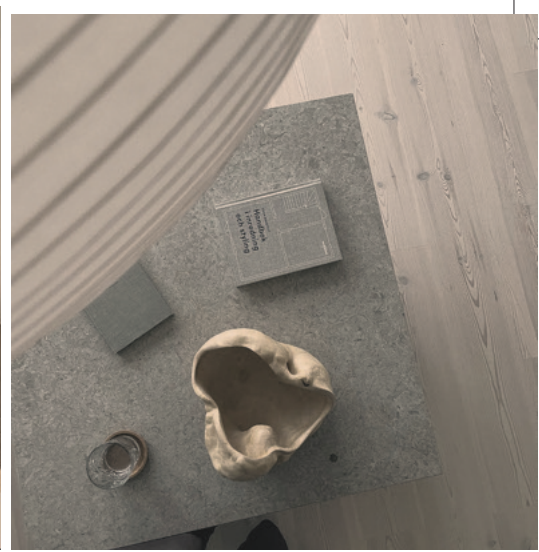
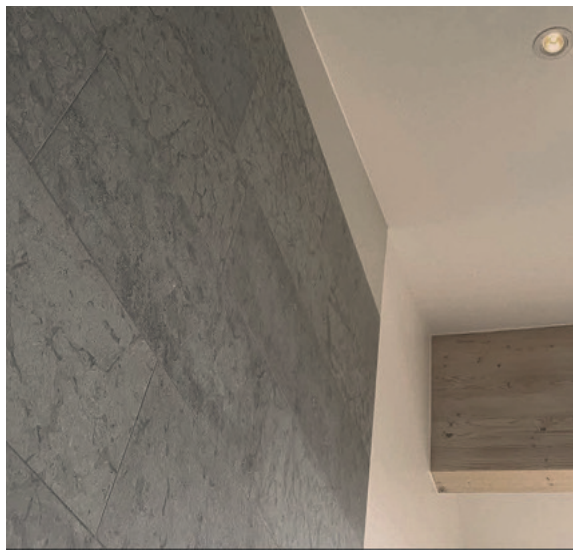

**REVAL
STONE**



VILLA APPEL
Reval honed



VILLA APPEL

more references in Scandinavia

In Sweden

- Lunds Tingsrätt. Reval limestone facade (800 m²), internal floors (1300 m²), stairs (985 steps), and 170 window sills. Tingsrättsplatsen 2, Lund.
- Nya Kronan office building. Reval honed floor tiles (3000 m²) and stairs (more than 1000 steps). Stockholm.
- The new Malmö's Tingsrätt. Brushed Reval antique (3000 m² floor tiles). Nyhamnen, Malmö.
- Selgase dolomite facade of a private residence. Falsterbo, Malmö.
- Stairs and floors of many private residences – Orgita dolomite and Reval limestone.

In Norway

- Facades and floors of private residences – Kaarma dolomite and Reval limestone.

In Finland

- Sello Library – Reval limestone floor. Kauppakeskus Sello, Leppävaarankatu 9, Espoo.
- Iittala store – Reval limestone floor. Tampere.
- The building of the Bank of Finland – dolomite floor. Helsinki.
- Turku Archipelago Central Building – limestone floor. Korpo.

REVAL STONE

LIMESTONE FACTORIES OF ESTONIA



References in LATVIA

Reval Scratched



REVAL
STONE



ESTONIAN EMBASSY IN RIGA

Kaarma dolomite facade
Latvian Architectural Award 2025

more references in Baltics

In Latvia

- The main building of Riga Hydroelectric Power Plant – Kaarma dolomite facade. Riga.
- Shopping centre Driangulas Bastions – Orgita dolomite facade. Riga.
- Facades of private residences – Reval limestone, Kaarma, and Orgita dolomite. Riga and Jurmala.
- Rumene manor – Orgita dolomite floors, dolomite stairs and dolomite back terrace.
- Commercial building – dolomite stairs and landings. Palasta street 9, Riga.

In Lithuania

- Reval hotel LIETUVA – Orgita dolomite facade. Ukmerges street, Vilnius.
- Facades of private residences – Orgita and Kaarma dolomite.
- Monastery of Bethlehem – dolomite floor and stairs.

REVAL STONE

LIMESTONE FACTORIES OF ESTONIA



Tallinn / Reval limestone facade



Tallinn / Orgita dolomite facade



Tingsrätten Lund / Reval limestone facade



Tallinn / Kaarma dolomite facade



Harju County / Reval limestone facade



Tallinn / Reval limestone facade



Tallinn / Kaarma dolomite



Harju County / Reval limestone element



Tallinn / Orgita dolomite



Harju County / Reval limestone facade



Tallinn / Kaarma dolomite



Tallinn / Reval limestone





Riga / Orgita dolomite facade

walls and facades

Building from stone

To build from stone is to choose the oldest and most considered way of making something permanent. It is a decision that values what endures — the quiet authority of natural material, the beauty that deepens with age rather than fades.

Stone does not demand much of you over a lifetime. It asks only to be chosen well. In return, it offers genuine durability, a richness of colour that is entirely its own, and a presence no manufactured surface can replicate. Its value does not diminish. It becomes part of the story of a place.

This is what it means to build from stone.



Harju County / Vasalemma Manor / Reval limestone facade

We offer several types of solutions for external walls

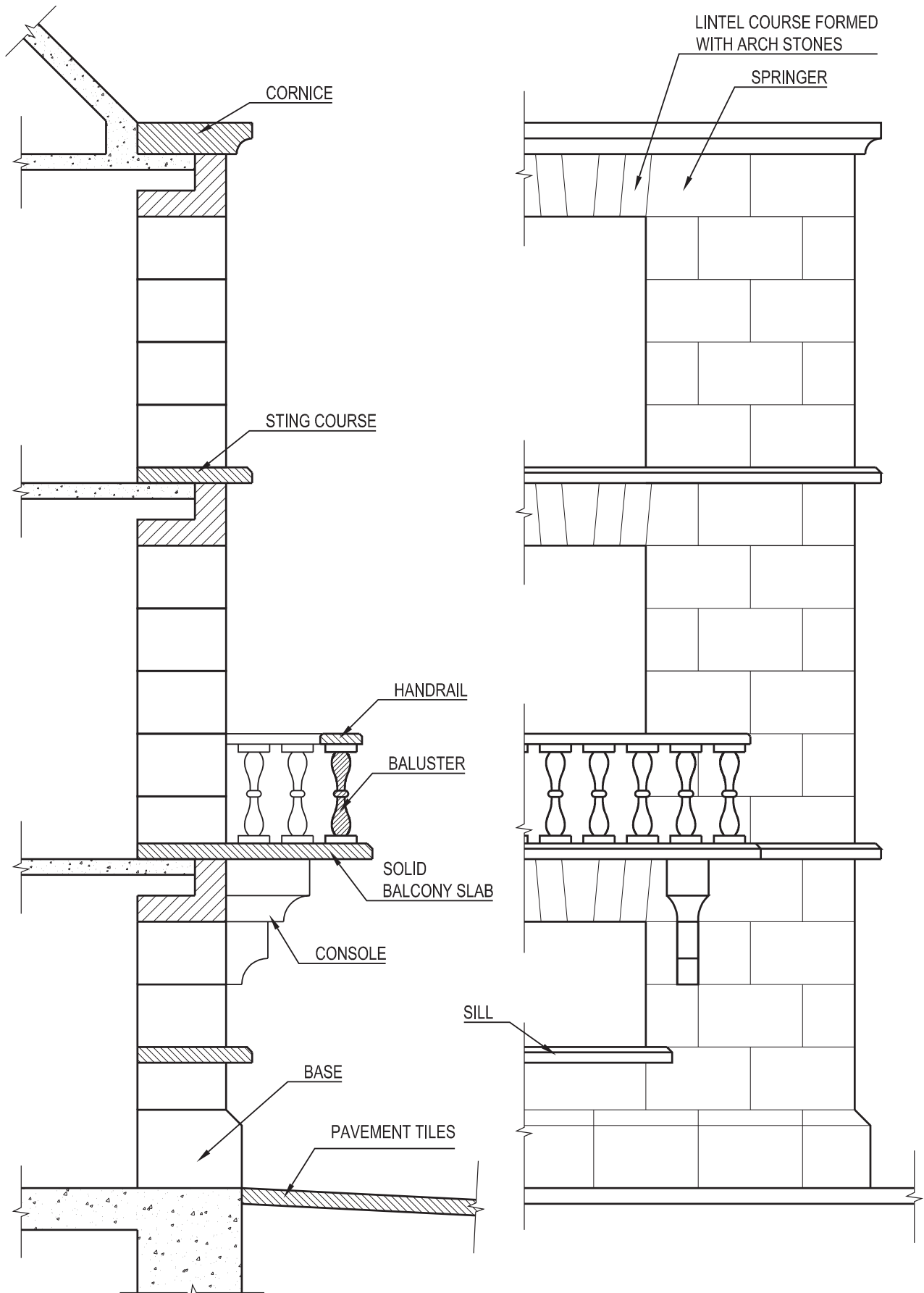

Stone wall with external insulation

Insulation of external walls has the following advantages:

- saving energy by lessening heat bridges
- good water resistance
- no condensate
- more residential space

1. Facades (classical and modern)

The facade is the first thing a building says about itself. Stone says it quietly, without needing to compete — its credibility is geological. What has taken millions of years to form does not need embellishment. It only needs to be placed well.

1.1. Self-bearing masonries

1.2. Panel facades

1.3. Panel facades pasted with mixture

Let's take a look and choose the most suitable one. We will describe them in detail.



Malmö / dolomite facade

Choice of materials

- Choice of natural stones according to situation and conditions
- Minimum thickness (depth)
- Maximum height of the facade

Width of joints:

- joints between stones
- deformation joints

Building masonry: anchoring the choice and density of anchors per square meter

Suggestion: account for natural facade stones already when designing. Redesigning means additional costs.



Tallinn / Orgita dolomite facade

1.1. Self-bearing masonries

Definition:

- 3–12 cm cover made of natural stone bricks attached to the building's stable wall construction. Galvanized or stainless steel wire anchors can be used as fixing methods (\varnothing 3–4 mm, 4 pieces per square meter).
- The used fixing method must enable the natural movement of facade stones in deformation conditions created by several factors (wind load, temperature, and other typical local conditions).
- The choice of method is limited by the building's height but not its size, and it depends on the thickness of the stones.
- In the case of ventilated facades, a 20–40 mm gap must be left between the backside of the facade stone and the building's external construction.

Choice of stones:

- Natural stone bricks are a unique facade material.
- Chosen according to standard EN 771-6:2005 Natural stone masonry unit.
- Brick thickness depends on the material, dimensions, and fixing method of the stone. Fixing method depends on the environment, location, and other factors that the stone wall must be able to resist.

Suitable materials

- Kaarma dolomite
- Selgase dolomite
- Orgita dolomite
- Reval limestone

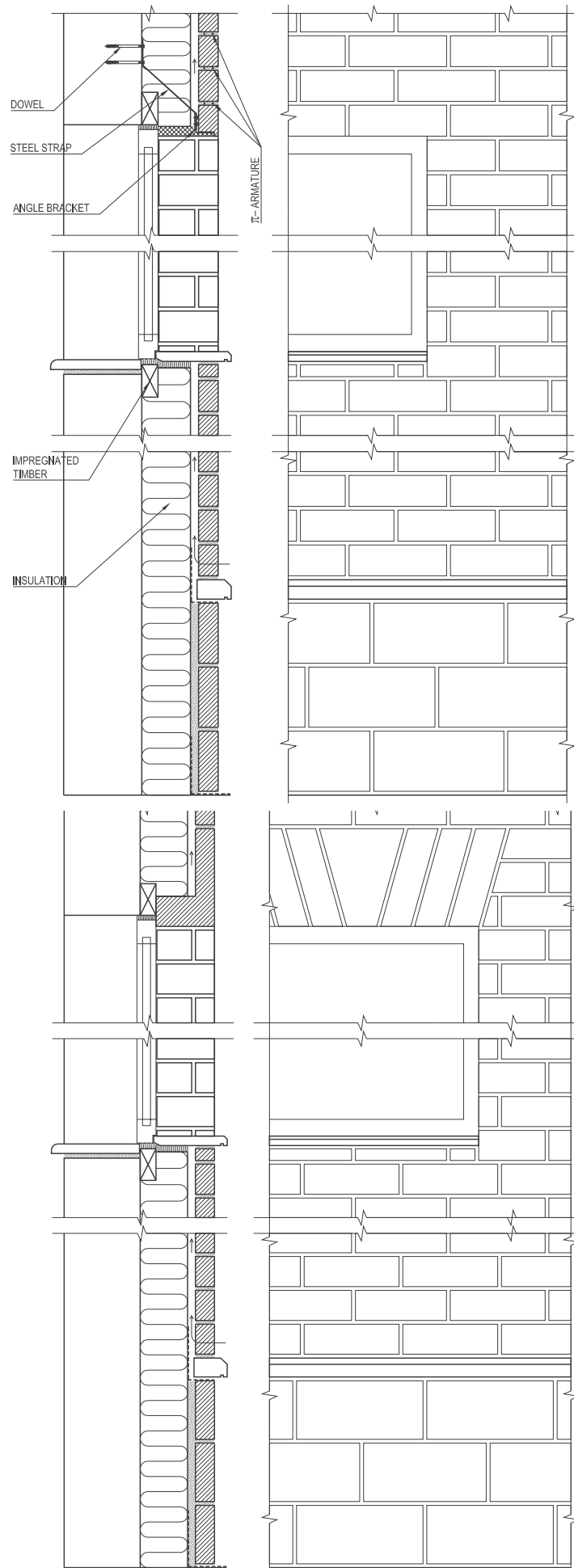

Qualities of dolomite and limestone masonry stones:

- Compressive strength
- Frost (freeze/thaw) resistance
- Open porosity
- Apparent density

Installation:

ordinary masonry mixture or, depending on the situation, mixtures based on lime mortar can be used for masonry works

Overlay of the masonry stones in masonry:

generally it is required that the overlay of the masonry stones must be at least $\frac{1}{4}$ of the thickness of the stone, and no less than 40 mm.

Ventilation gaps in masonry:

- there are vertical joints per each meter in the first or second row of the masonry (depending on the situation) that are generally left open, and in the same manner the upper edge per each floor should, depending on the construction, be left open and ventilated.
- when building a masonry, it is useful to use masonry stones from 3–4 different pallets to disperse various shades.
- masonry stones must not be moved after adhesion.
- temporary disjunctions of masonry works must be gradual.
- mortar splashes must be removed from the surface of the masonry before the mortar has hardened.

Newly built masonry:

- When construction works are interrupted, the top level of the masonry that is not yet finished must be protected from rain and moisture.
- In dry and hot weather the masonry must be prevented from drying too quickly.
- Newly built masonry must be protected from hazardous influences, such as wind and horizontal load from scaffolding, rainfall, melting snow, freezing, etc.
- Newly built masonry must be prevented from freezing so that it would not slump, incline, crack or suffer any other damage while thawing.

- the recommended thickness of joint is 8–12 mm, depending on the dimensions of the chosen stones.
- a 20–40 mm air gap must be left between the external wall and insulation.
- every 3–4th vertical joint of the lower and upper stone row of external wall must be left without mortar in order to provide ventilation.
- external wall will be attached to the bearing structure with stainless steel anchors: \varnothing 3–4 mm, 4 pieces per square meter
- mortar beds of external wall will be reinforced after the first stone row and below the last row; and, depending on the bridges, multiple times under and on top of the masonry gaps.
- fences and external barriers are isolated from the foundation with moisture insulation.
- the top level of the fence will be protected from weather conditions (for example with cover plates from natural stone).

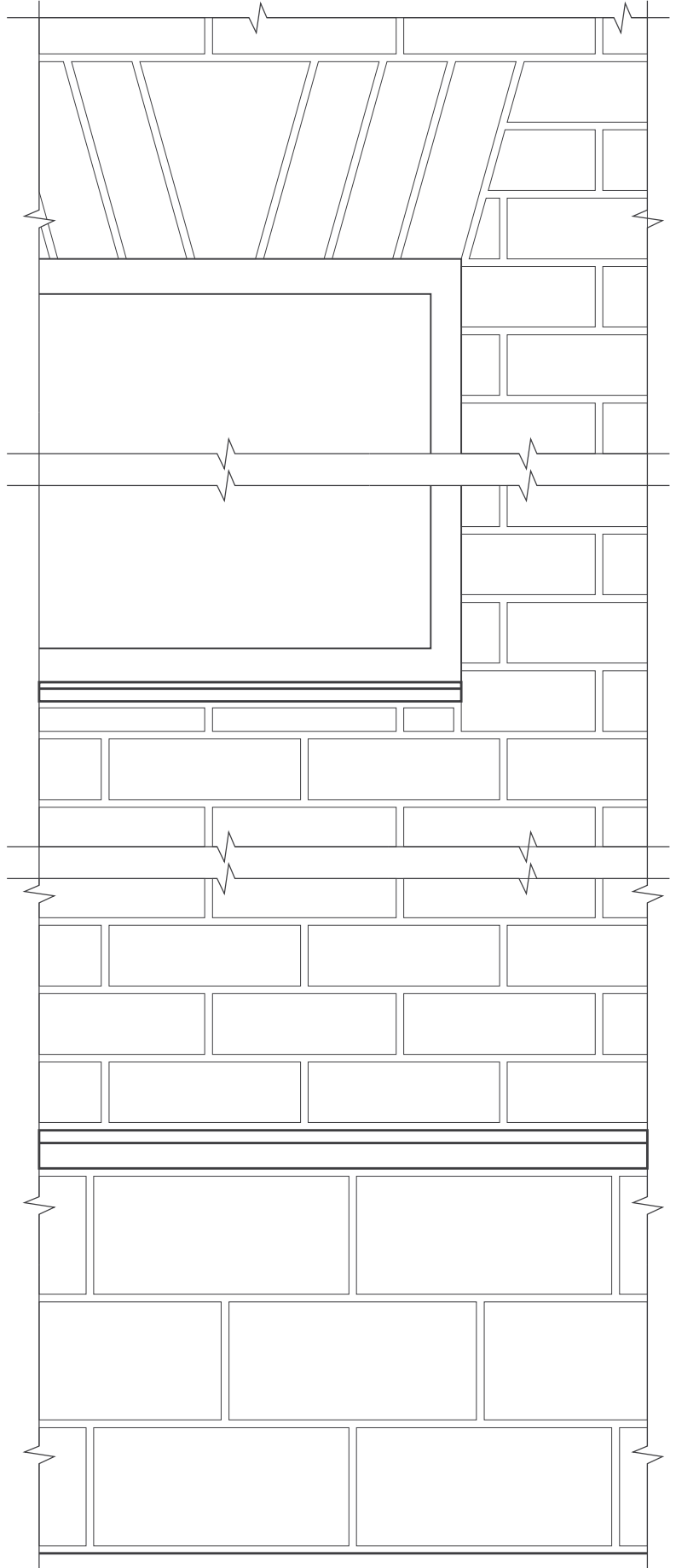
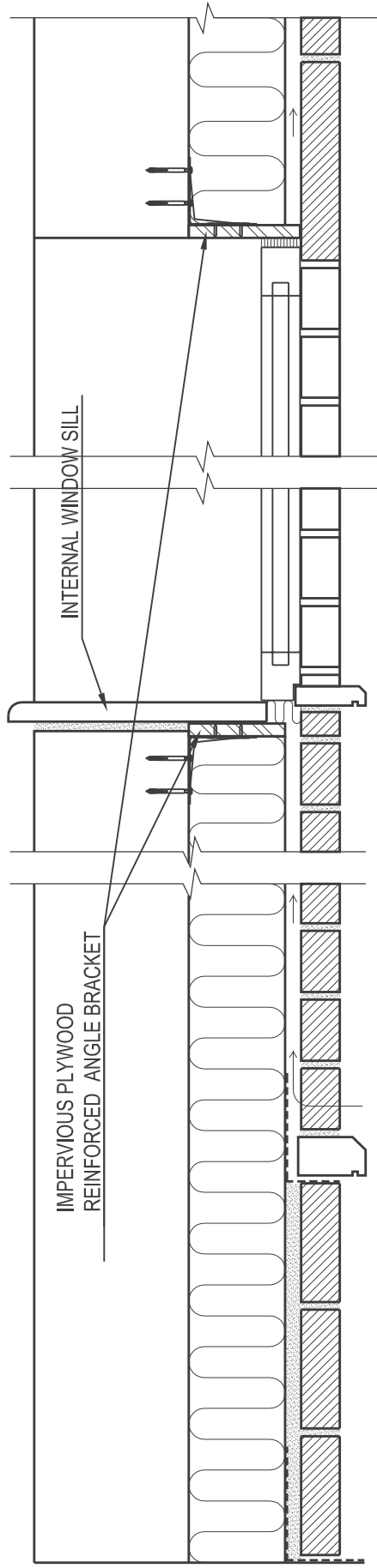

1.2. panel facades

a thin natural stone cover attached to the building's stable wall construction.

- The thickness of the cover is usually 30–50 mm. Fixings must be from stainless steel, aluminum, hot-dip galvanized steel.
- There are two fixing methods: either by fixing the tiles on metal frame, or by installing them on anchors that are drilled in the concrete wall.
- Metal fixings that are in direct contact with natural stone must be from stainless steel.
- The used fixing method must enable the minimal natural movement of the facade tiles in different conditions (wind load, temperature, and other conditions).
- The use of the given methods is not limited by the height or size of the building.
- The width of the joints between tiles is usually 8–10 mm.
- Joints may be left open or filled with special elastic and weatherproof joint mixture.
- In the case of ventilated facades, a 20–30 mm gap must be left between the backside of the tile and the building's external construction.

Choice of stones:

- Chosen according to standard EN 1469:2005 Slabs for cladding.
- Dimensions depend on the material of the stone and the fixing method, which in turn depends on the location and the environment the stone wall has to be able to resist.

Suitable materials:

- Kaarma dolomite
- Selgase dolomite
- Orgita dolomite
- Reval limestone

Choice of fixing methods:

1.2.1. ventilated facade on mechanical anchors:

1.2.2. ventilated facade on hot-dip galvanized frames (with insulation) with stainless steel splines

1.2.3. ventilated facade type "Reval Stone" on hot-dip galvanized frames (with insulation) with stainless steel clips

1.2.4. ventilated facade on mixture anchors:



The image shows the exterior of the Hotel Euroopa in Tallinn. The building's facade is composed of light-colored, horizontally-oriented panels. A grid of windows is visible, with each window having a dark frame and light-colored curtains. The name 'Hotell Euroopa' is displayed in a white, cursive script across the middle of the facade. Below the name is a glass entrance with a revolving door and a canopy. The interior of the entrance is visible through the glass, showing a reception area with a desk and chairs. The overall appearance is modern and clean.

Hotell Euroopa

Tallinn / Orgita dolomite facade

1.2.1. ventilated facade on mechanical anchors:

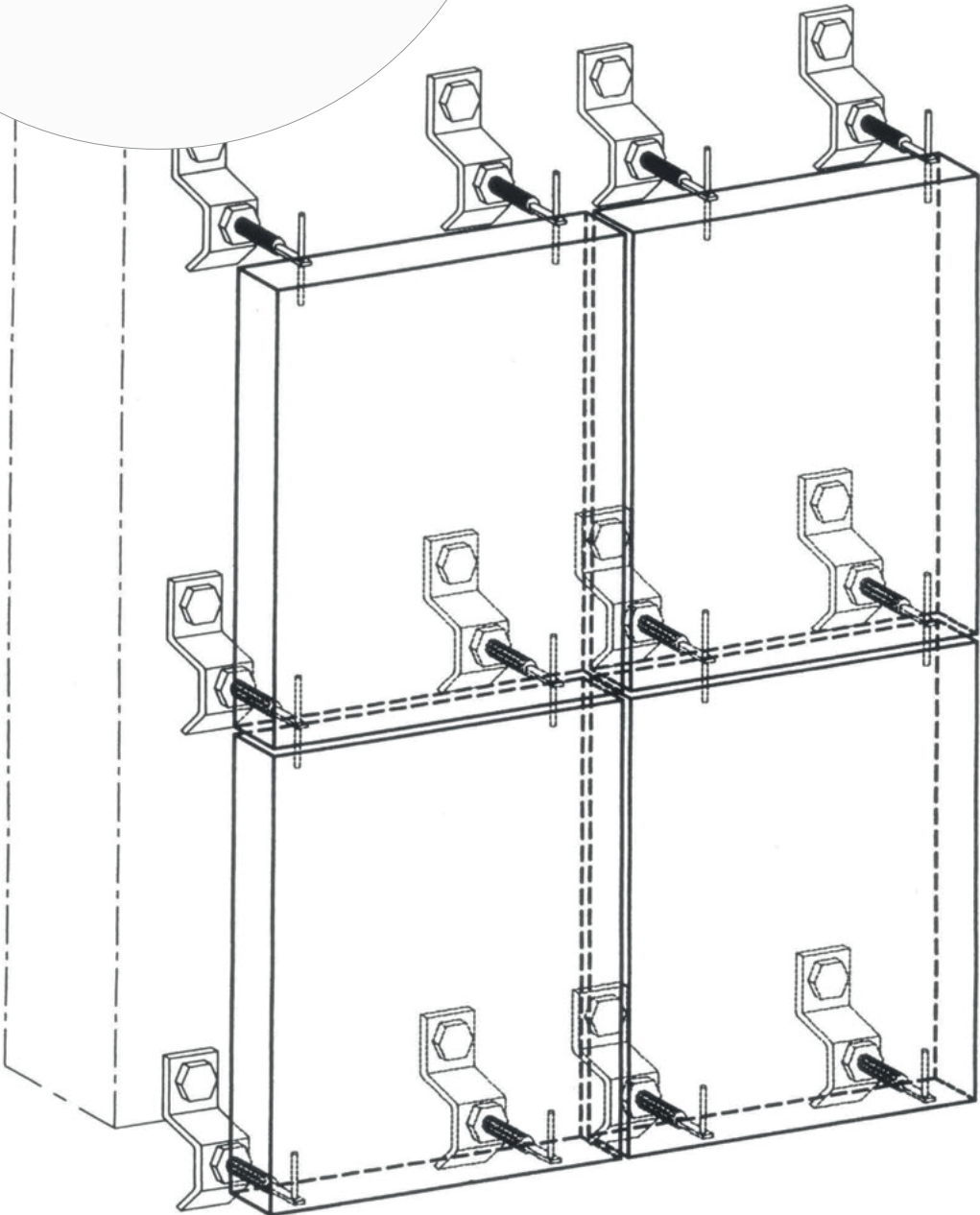
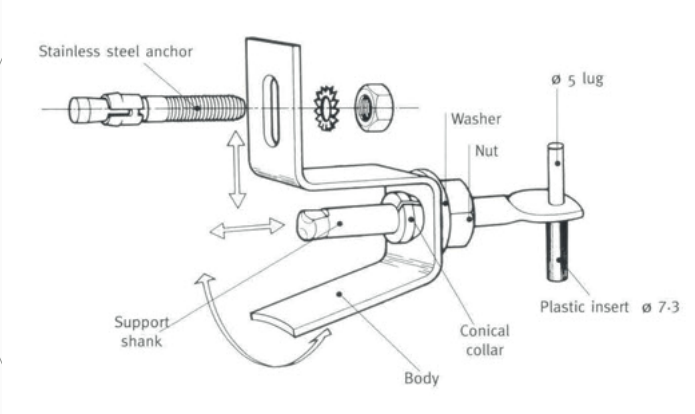

1.2.2 ventilated facade on hot-dip galvanized frames (with insulation) with stainless steel splines:

It is possible to get a panel facade with insulation:

1. when the panel facade is attached directly to the base wall;
2. when the panel facade is attached to a previously insulated wall.

Number of anchors: usually 4 pieces per panel (2 bearing + 2 sustaining)

Air gap: wider than 20 mm

Gaps for fixing splines:

- Holes in the panel must be 0.5–3 mm bigger than the stainless steel splines, and they must be located 10–20 cm from the corners.
- The axis of the hole must be in the centre of the panel thickness and about $L/5$ away from the corner.
- The thickness of the stone from the edge of the hole to the edge of the panel must be at least 10 mm in the case of a 3 cm panel.
- The depth of the hole must be at least 30 mm in the case of a 5 mm spline, and the spline must extend in the stone for at least 20–25 mm.

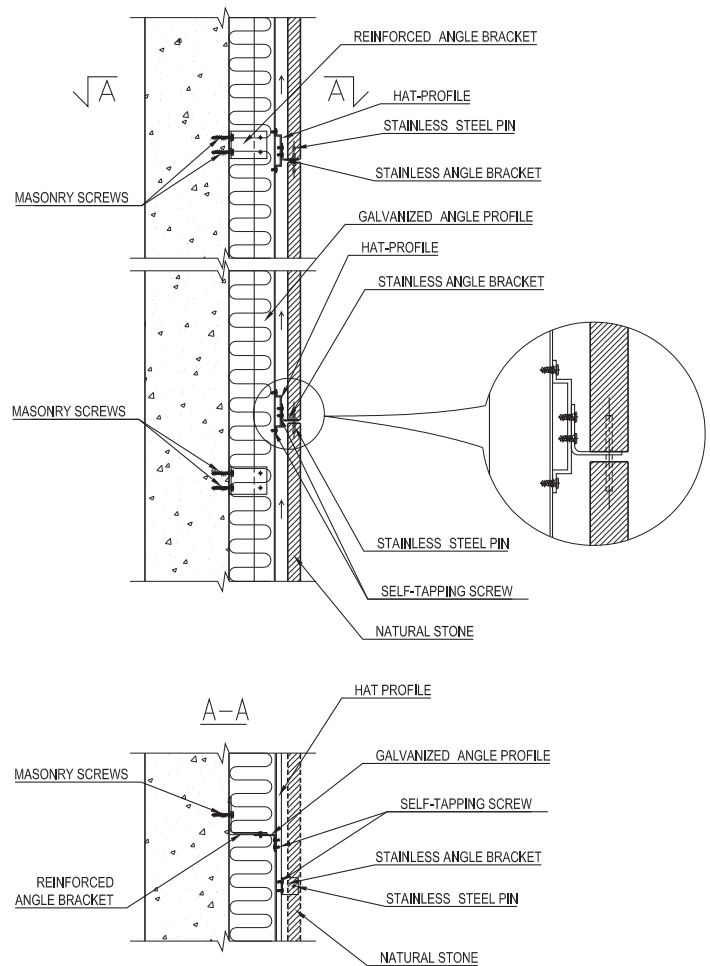

Adjusting splines:

The hole must be 0.5–1 mm bigger, and before the spline is inserted, the hole is filled with a special mixture or glue.

Joints:

They are either left open or filled with a special elastic joint filling.

Expansion joints:

Should be as wide as and in same direction as the panels. They are left open or filled with special joint mastics.

Architectural and constructional joints:

- Joints that are determined by base constructions.
- There should be a joint per each floor when the joints are filled with mixture (for example, up to 10 mm open joints or horizontal joints with special mastic should be 3 m apart).

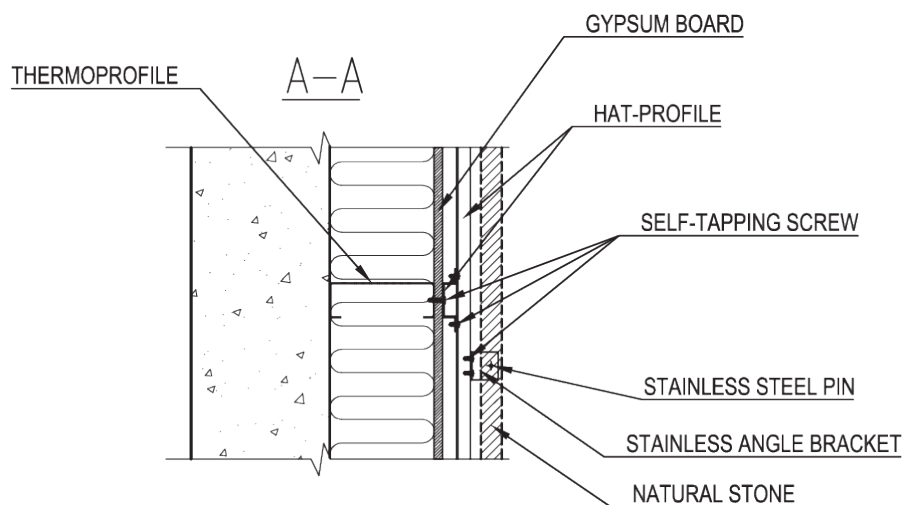
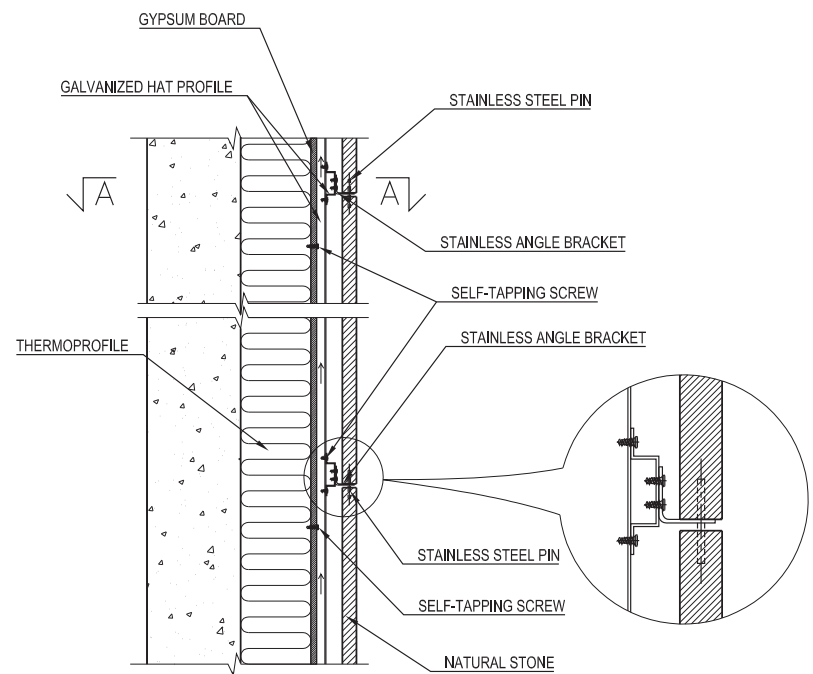

1.2.3 ventilated facade type "Reval Stone" on hot-dip galvanized frames (with insulation) with stainless steel clips

Panel facade from natural stone that emphasizes horizontal joints and does not need elastic filling joints.

Number of clips: usually 4 pieces per panel (2 bearing + 2 sustaining)

Air gap: wider than 20 mm

Adjusting clips: Clips are adjusted with plastic wedges, using stone glue and mastics for fixing.

Joints:

- Vertical joints are usually left open and are minimal between stone panels (stone panels are installed right next to each other).
- The width of horizontal joints can be adjusted by the client. The same natural stone is visible through the joint.

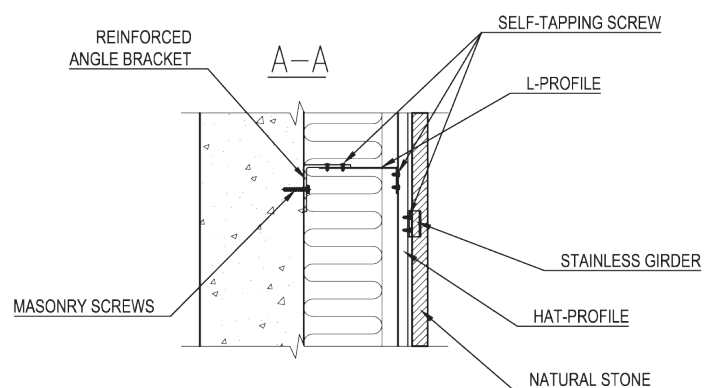
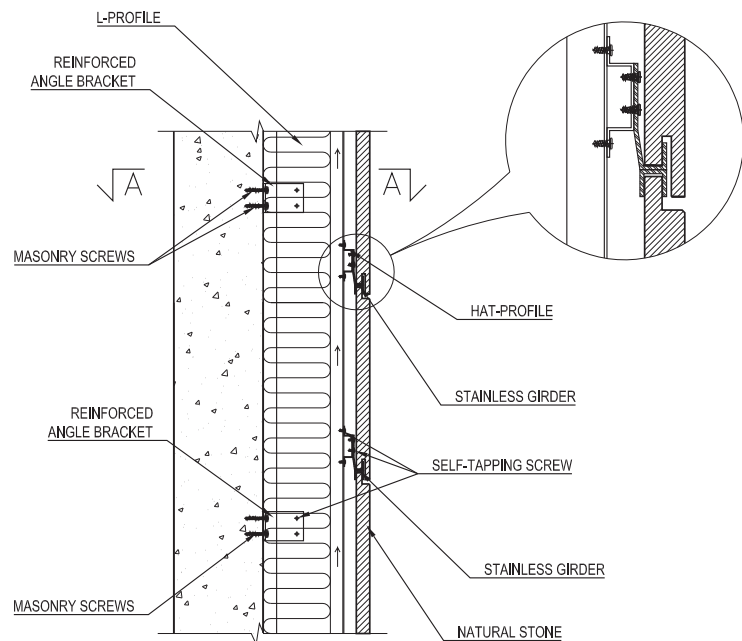

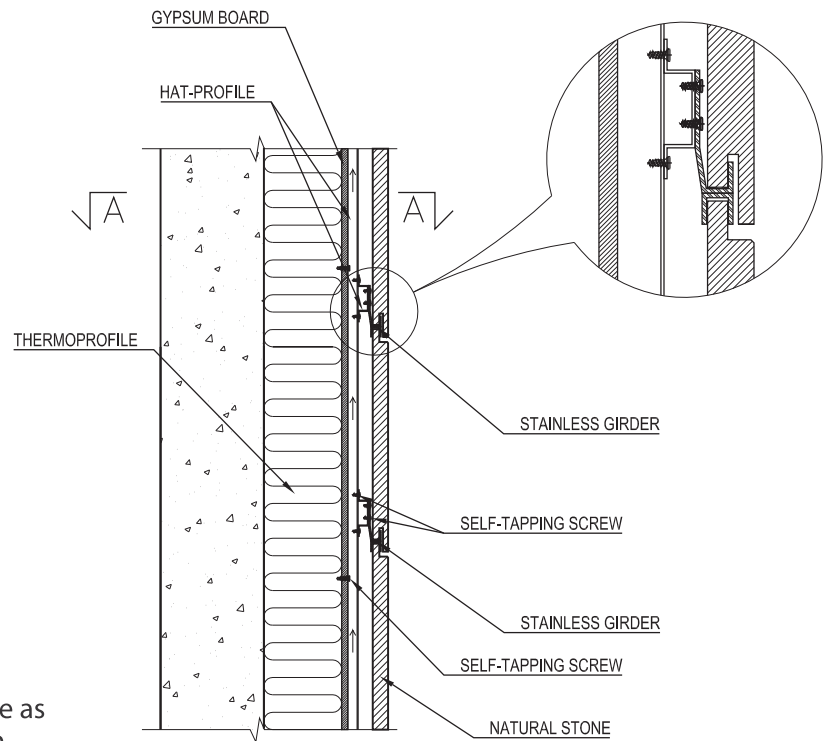

Expansion joints:

- They should be in the same place as the base construction expansion joints (the width depends on the base construction and technical factors). They are either left open or filled with special joint mastics.
- Horizontal expansion joints are needed for every 24 meters. They are determined by technical conditions and the particular situation.

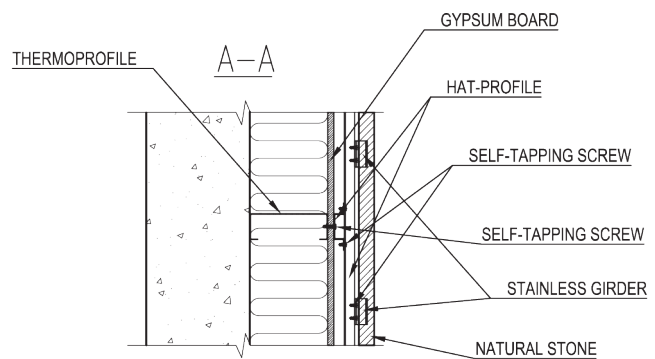

1.2.4. ventilated facade on mixture anchors:

Natural stone panels are attached to the stable retaining construction with metal anchors that are attached to the retaining wall with special mixtures.

Choice of materials:

Depends on the client as well as on base constructions, technical conditions, and the location (wind load, weather conditions, etc).

Type of retaining wall: concrete is the best option, other variants (hollow brick is not recommended)

Height: Preferably up to 28 m, if the joints are filled with mixture.

Requirements for the retaining wall: Flatness should not vary more than 2 cm.

Anchors:

Vertical and horizontal stainless steel anchors whose wall-facing ends are rotated 90°.

Number: 4 pieces, 2 of which are bearing and 2 sustaining

Air gap: the gap between the back side of the natural stone and the retaining wall or insulation must exceed 2 cm.

Fixing the anchors to the retaining wall:

special mixtures are used to attach the anchor to the pre-drilled holes in the retaining wall whose diameter is up to 3 cm and depth up to 8 cm.

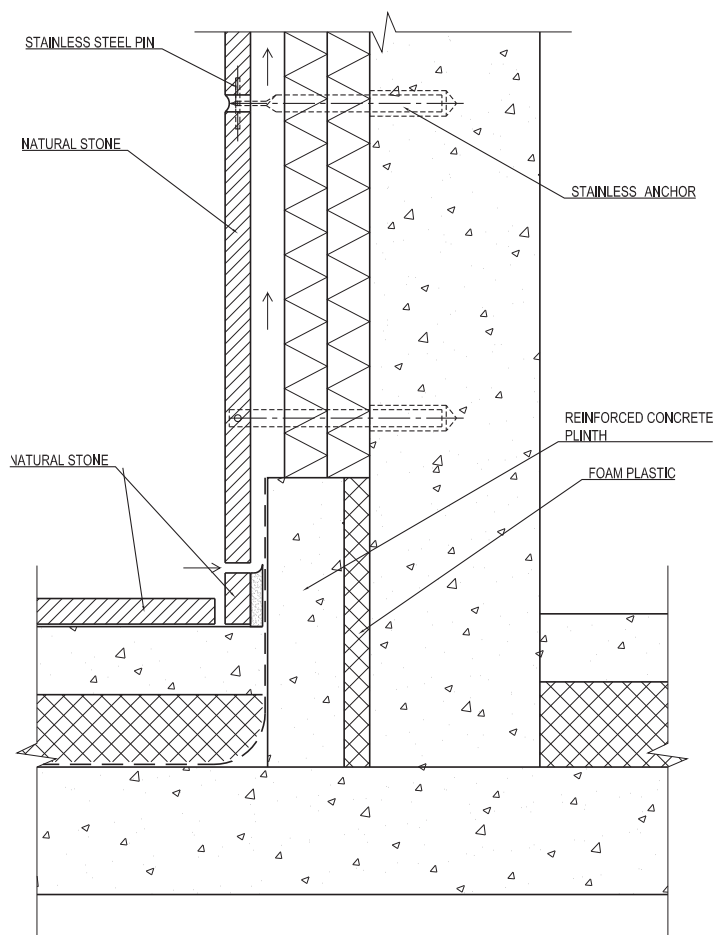

Suitable materials:

- Kaarma dolomite
- Selgase dolomite
- Orgita dolomite
- Reval limestone

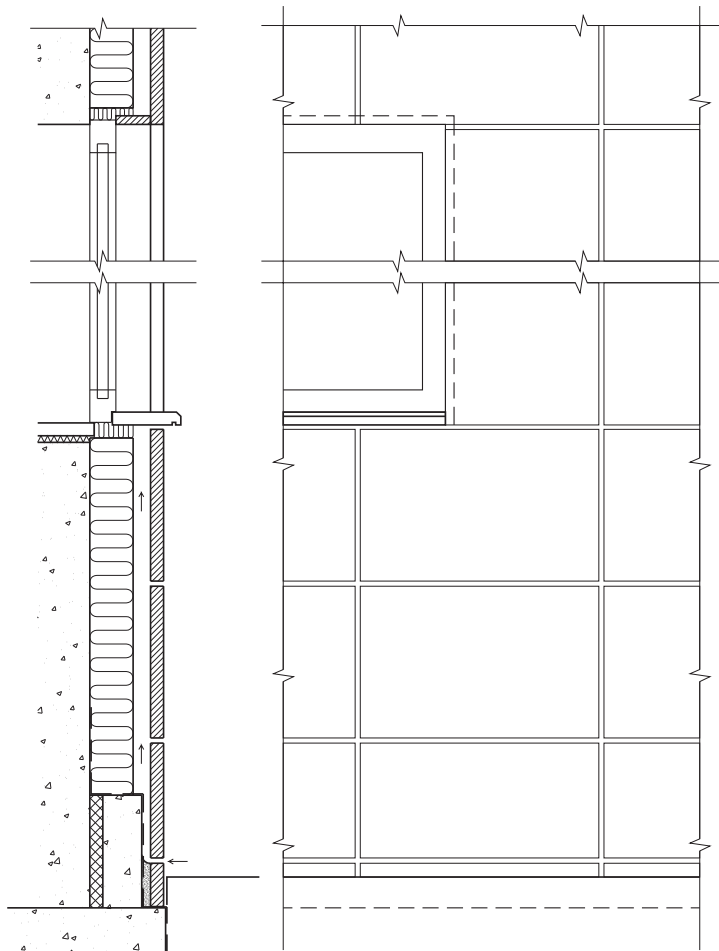

Plate anchor fixing:

Natural stone panels are attached to the anchors with stainless steel spline that is inserted in the holes that are drilled 10–20 cm away from the corners of the panel. The diameter of the hole must be 0.5–3 mm bigger than the diameter of the spline.

Installation holes must be drilled as follows:

- The axis of the hole must be in the centre of the panel thickness and about $L/5$ away from the corners.
- The thickness of the stone from the edge of the hole to the edge of the panel must be at least 1 cm in the case of a 3 cm panel.
- The depth of the hole must be at least 30 mm, and it should be 5 mm deeper than the end of the spline that is inserted in the stone.

Adjusting splines:

- splines can be adjusted in both directions, if the hole of the spline is up to 10 mm deeper.
- before inserting the spline the hole is filed with a special mixture or mastic.

Joints:

They might be left open or filled with elastic mastic (for example urethane mastic). Do not use mastics that contain silicone oil, these will later leave thin, dark, oily marks around the edges of the panels.

Expansion joints:

They should at least run in the same direction as joints, and their width should be as same as or slightly wider than that of the joints.

Distributional or dividable joints:

- If the joints are filled with mixture, one horizontal joint for each 3 meters or per floor should be left open or be later filled with special mastic.
- Elastic vertical joints should be approximately 6–8 m apart. Minimal width of horizontal joints is 10 mm.
- Both are usually filled with elastic. Minimal width of vertical joints is 8 mm mastic.

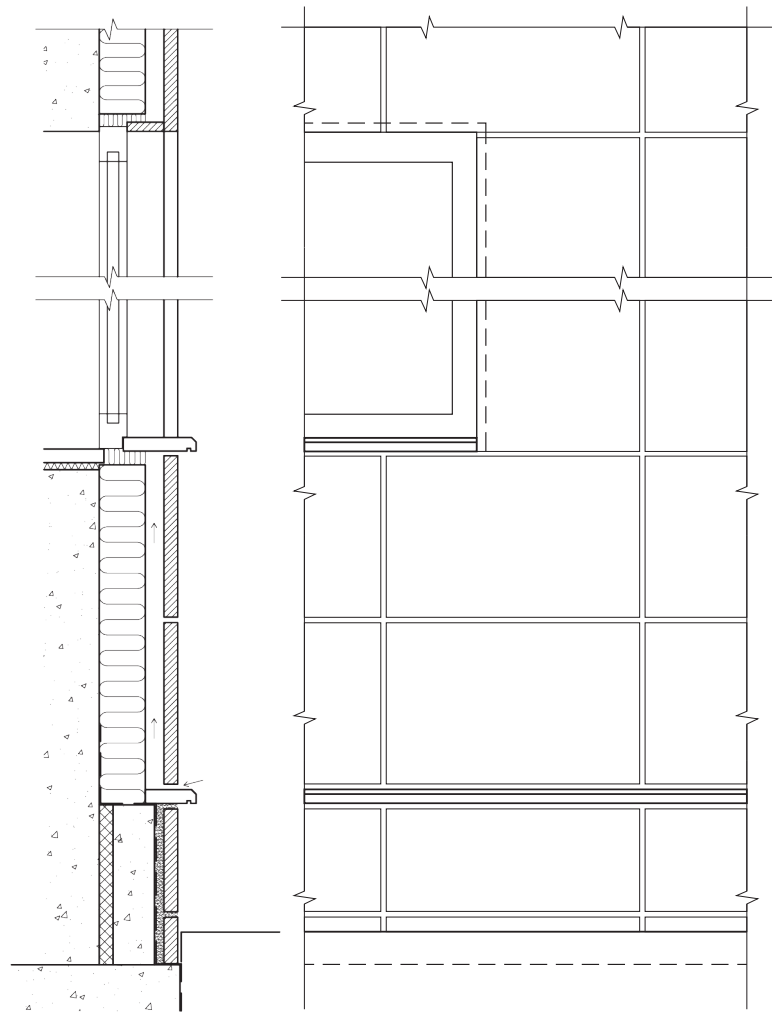

1.3. panel facades pasted with mixture

Covering the internal and external facades with natural stone panels, using glue mixture.

Choice of materials:

Similar to previous. The dimensions of the panel must take into account the weight of the material, the qualities of the glue mixture, the height of the construction, the fixing method, and the base construction.

Suitable materials:

- Kaarma dolomite
- Selgase dolomite
- Orgita dolomite
- Reval limestone

Type of the retaining wall

Possible options in external conditions: reinforced concrete that is 2–3 months old and plastered with cement mixture, or 3 weeks old masonry with mixed mixture.

In the interior other retaining wall types can be used, such as plastered surfaces, gypsum walls, lightweight blocks walls, etc, that are in accordance with the technical requirements.

Evenness:

Generally the retaining wall must be carefully prepared and meet the standards. For example: in case of plastered or concrete wall the evenness should be less than +/- 3 mm in the case of a 2 m bar.

Cleanliness:

The wall to be covered with panels must be clean and previously undercoated with bond dispersion corresponding to the used mixtures. The wall must not be dusty or oily.

Humidity:

Gluing must be performed on a slightly moist base wall. In hot weather when the humidity is low or the base wall is very porous, it should be slightly moistened before gluing.

Temperature: The panels must not be glued on a wall with temperature below +5°C or above +30°C.

Choice of glue mixtures:

When gluing the facade stones, mixtures should be used that do not stain the stone and that correspond to the technical requirements. Use glue mixtures intended for use with natural stones.

Joints

Expansion joints:

Should be as wide as and located in the same manner as the rest of the facade joints. They should follow the expansion joints of the base construction as closely as possible.

Dividable joints:

Joints must be at least 5 mm wide, and filled with decay resistant elastic joint mastic that does not stain the stones. It is advisable to create horizontal dividable joints 3 m apart (or one per floor) and vertical joints 6–8 m apart.

Joints:

- Joints are filled with mortar, traditional joint mixture, or other special joint product that corresponds to the technical requirements.
- The width in internal walls is at least 1 mm
- The width in external walls is at least 2 mm, preferably 5 mm.

Protection of the top edges of panel facades:

The top edges of the vertical part of the external facade must be protected in an appropriate manner (cornice, etc) to prevent rain from leaking behind the stones.



Stockholm, Reval limestone floor, photo by Peter Werner

floors, staircases, skirting boards



2.1. floors

Stone floors carry the memory of every room they have ever been part of. Laid once, they outlive trends, fashions, and renovations — becoming more beautiful as everything around them changes.

Stone floors are:

- easy to maintain
- wearproof
- installed in a traditional way
- provide a heating and acoustics solution
- offer you a wide choice of natural materials that match all interior design styles

The recommended thickness of the stone is determined by the base construction and the fixing method.

- floors installed on thick mixture
- floors installed on glue mixture

While 20–80 mm panels installed on the traditional thick mixture require 3–5 cm for installation, only 0.5–1 cm of space is needed by 10 mm panels installed on glue mixture.

This method allows for the replacing of thin flooring materials, such as carpets, parquet, etc.

But also installation on thick mixture has its positive sides:

- base levels do not have to be perfectly even
- perfectly horizontal
- this method is well suited for renovation

2.1.1. floors installed on thick mixture

2.1.2. floors installed on glue mixture

2.1.3. stone slabs on heated floors

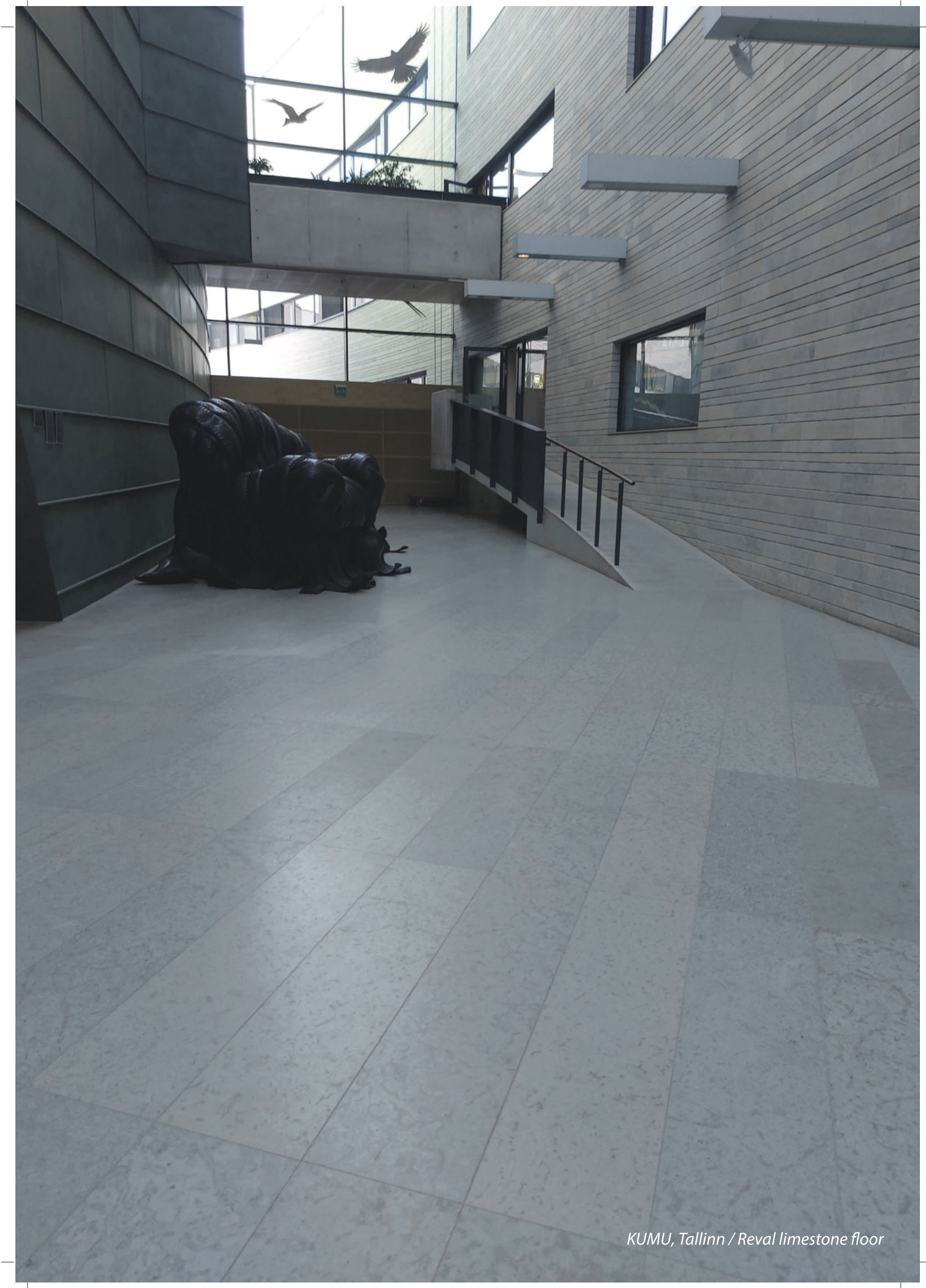

KUMU, Tallinn / Reval limestone floor

2.1.1. floors installed on thick mixture:

internal and external floors that are finished with natural stone floor panels fixed with cement mixture.

Choice of flooring:

- The chosen stone must be with adequate wearproof qualities depending on the intensity of use, and also weatherproof in external conditions.
- The thickness of the stone is determined by the strength and dimensions of the stone, and the previous situation.
- Chosen according to standard EN 12058:2004 Slabs for floors and stairs.

Standard dimensions: thickness:

2; 3 cm in interior

2; 3; 4 cm in exterior, except for roadways.

Length, width:

square-shaped 30x30 cm; 40x40 cm; 50x50 cm; 60x60 cm

undefined length in the range of 1–2.5 times the width

Bases

Preparation of the base:

Concrete slab, concrete floor, concrete slab for floor beams, floor blocks, wooden floors, steel floors, etc.

Installation material:

- variety of options, including sand, cement mixture, and concrete-based mixture
- the choice of installation material depends on the base and the function

Humidity-proof membrane, moisture insulation, and capillary gap:

a layer that interrupts the bond between the installation material and the base, or between mixture and the layers beneath, preventing the humidity from rising up.

Suitable materials:

- Reval limestone (interior)
- Kaarma dolomite
- Selgase dolomite
- Orgita dolomite

Fixing mixtures:

- washed river or quarry sand, with grain dimensions of 0.08/3 mm cement and/or lime that does not stain the stone (test before using)
- use as a layer up to 5 cm

Slope:

External pavement: ready-made pavement should have a certain slope to assure drainage (minimal slope 1%)

Joints:

Expansion joints: they must be through the base, fixing mixture, and stone panel.

Dividable joints:

they must be through the stones and fixing mixture, and filled with elastic mastic. also in internal floors, except for heated floors. elastic joints should be at least 10 mm in width, and designed for separating approximately 60 m² of floor surface.

External pavement:

elastic distributional joints should be at least 10 mm in width, and account for approximately 25 m² of floor surface.

Peripheral joints

- at least 3 mm in width for interior and 10 mm in width for exterior
- filled with elastic mastic

Joints:

- joints filled with mortar, strong cement mixture, or ready-to-use joint mixtures
- in internal floors installation without joints is prohibited
- joints should be at least 1–3 mm
- external pavement requires joints at least 3–5 mm in width, depending on the technology.
- internal and external floors that are finished with slate, dolomite, granite, or marble floor slabs and fixed with glue mixture.

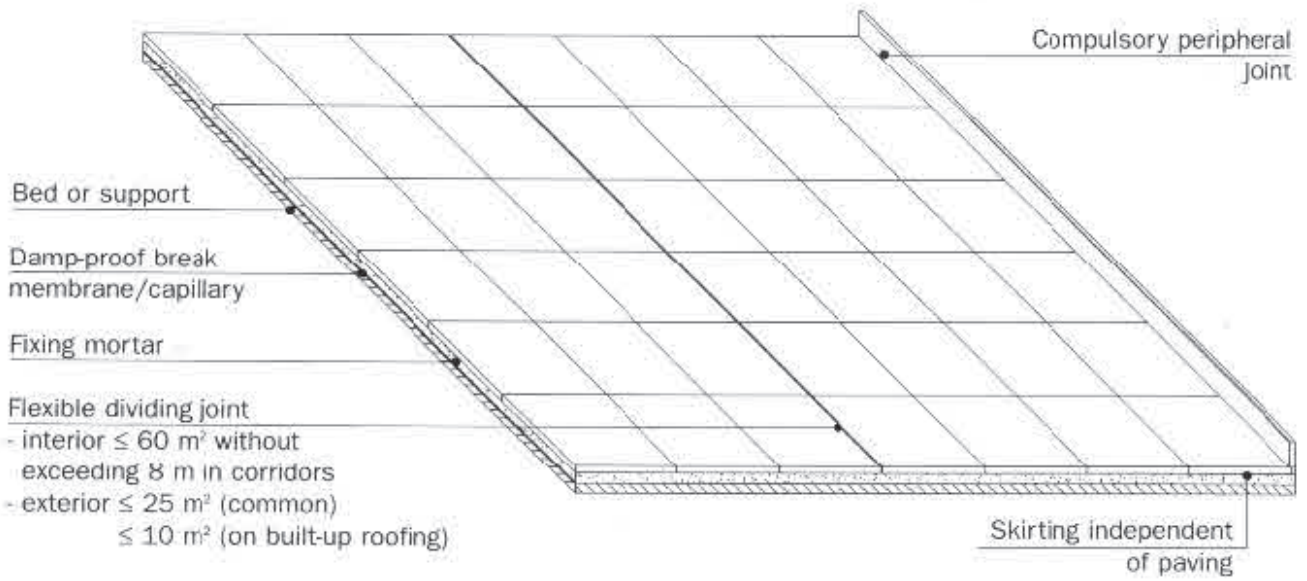

Rumene / Orgita dolomite mixed with dark limestone



Tallinn / Orgita dolomite

2.1.2. floors installed on glue mixture:

Choice of flooring:

- The chosen stone must be with adequate wearproof qualities depending on the intensity of use, and also weatherproof in external conditions.
- the thickness of the stone is determined by the compression strength, the dimensions of the stone, and the particular situation.
- chosen according to standard EN 12058:2004 Slabs for floors and stairs, or EN 12075:2004
- Modular tiles

Bases:

concrete slab, concrete floor, concrete slab for floor beams, floor blocks, wooden floors, steel floors, etc.

Evenness:

base surfaces must be even (unevenness should not be more than +/- 3 mm per 2 metres).

Suitable materials:

- Reval limestone (interior)
- Kaarma dolomite
- Selgase dolomite
- Orgita dolomite

Slope:

External Pavement: ready-made pavement should have a certain slope to assure drainage (minimal slope 1%).

Cleanliness:

base surfaces must be completely clean and dust free, and previously undercoated with bond dispersion corresponding to the used mixtures.

Humidity:

base surfaces must be dry.

Temperature: at least +5°C degrees.

Age of the base: concrete base must be at least 30 days old.

Choice of fixing mixtures:

depends on the location and the technical requirements.

Joints:

Expansion joint:

they must be through the base, fixing mixture, and stone panel.



Rumene / Orgita dolomite

2.1.3. stone slabs on heated floors:

Dividable joints:

- they must be through the stones and fixing mixture, and filled with elastic mastic.
- elastic joints should be at least 10 mm in width and they are designed for separating approximately 60 m² of floor surface.

External pavement:

elastic distributional joints should be at least 10 mm in width and account for approximately 25 m² of floor surface.

Peripheral joints:

- they must be at least 3 mm in width for interior and 10 mm in width for exterior.
- filled with elastic mastic.

Joints:

- joints filled with mortar, strong cement mixture, or ready-to-use joint mixtures.
- in internal floors installation without joints is prohibited.
- joints should be at least 1–3 mm.
- external pavement requires joints at least 3–5 mm in width, depending on the technology.
- internal and external floors that are finished with natural stone floor panels fixed with glue mixture.

Precautions that should be taken.

In order to prevent problems arising from the heating of the floor we suggest you follow these instructions:

- concrete takes at least 2 months to dry when the heating is turned on during the second month.
- it is also advisable to heat the base floor to maximum temperature twice.
- the base must be dry before the installation of the stones.
- peripheral joints must be elastic or open, and their width must be at least 5 mm.
- expansion joints must be accounted for in the floor.
- dividable joints should account for surfaces approximately 40 m² in size (through the width of the stone and mixture).
- heating elements (pipes, cables) are not to be installed into the fixing mixture.



Rumene / Orgita dolomite

2.2. staircases

Staircases include the usual horizontal stair slabs, as well as the vertical riser slabs.

Choice of materials:

- The chosen stone must be with adequate wearproof qualities depending on the intensity of use, and also weatherproof in external conditions.
- the thickness of the stone is determined by the dimensions, function and strength of the stone.
- Chosen according to standard EN 12058:2004 Slabs for floors and stairs.

Suitable materials:

- Reval limestone (interior)
- Kaarma dolomite
- Selgase dolomite
- Orgita dolomite

2.2.1. staircase installed on thick mixture

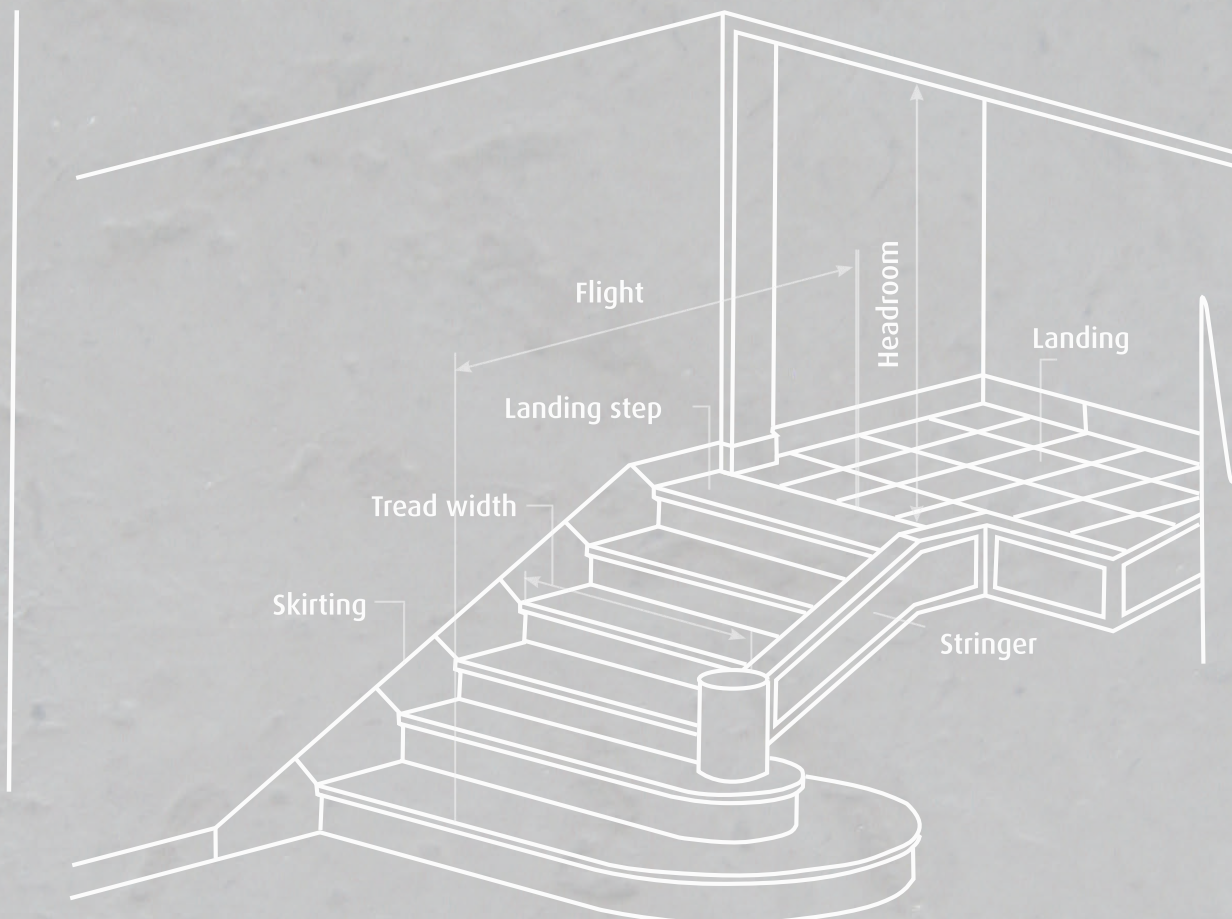

2.2.1. staircase installed on thick mixture:

Stairs:

- standard thickness: 2–3 cm, 5–8 cm with various front edge profiles.
- standard width: 30–35 cm in the case of straight stairs.
- standard length: 80–140 cm in the case of straight stairs, up to 200 mm in case of sector stairs.
- on request we can make stairs over 200 cm long.
- it is advisable to apply a non-skid processing to the staircases that are publicly used or in public places.

Riser slabs:

- standard thickness is 2 cm
- height range is 12–21 cm (usually 12–15 cm)

Standard reserves:

- stairs: the thickness of the stair panel
- + 3 cm for the mixture.
- risers: the thickness of the riser panel
- +2 cm for the mixture.

Fixing mixture:

- washed river or quarry sand, with grain dimensions
- of 0.08/3 mm.
- cement and/or lime that does not stain the stone (test before using).
- mixture proportions: 350 kg cement per 1 m³ dry sand.

Installation of handrails: (balustrades)

- handrails should be fixed/installed into the cement base.
- in a place where the fixing passes through the stair panel, a soft/flexible joint must be made.

Joints:

- Horizontal joints between the riser and stair slabs:
- the width exceeds or is equal to 1 mm.
- the joints are filled with joint mixtures that do not stain the stone.
- vertical joints can be put together in internal staircases or left minimal (1–2 mm).

Dividable joints:

filled with elastic mastic joint fill

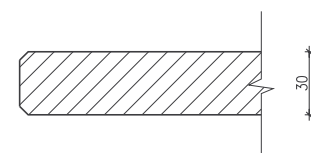
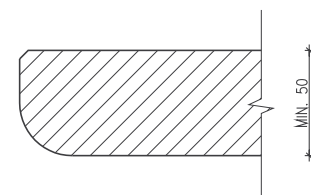
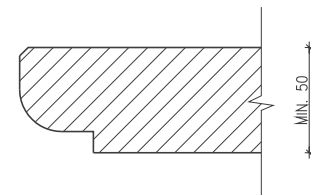
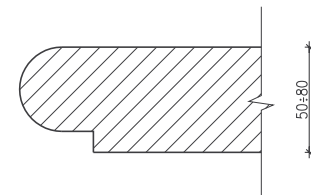
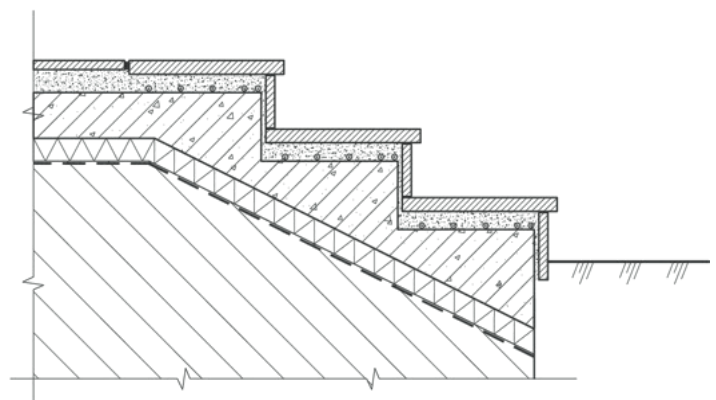
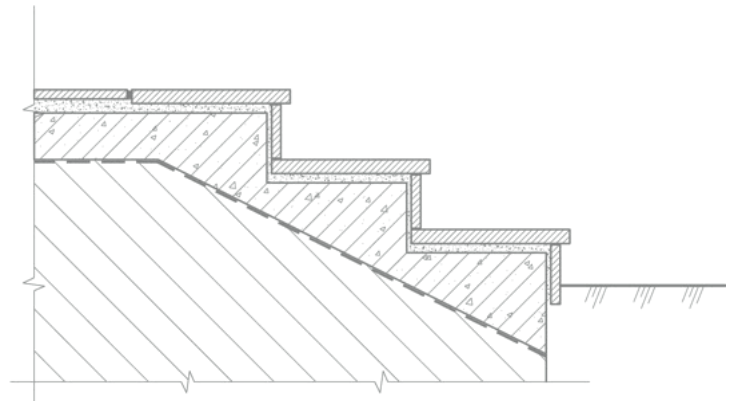

Staircase installed on thick mixture:

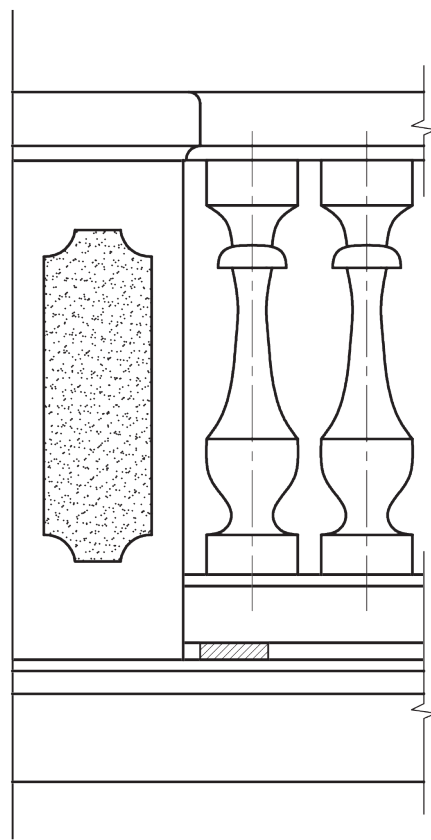
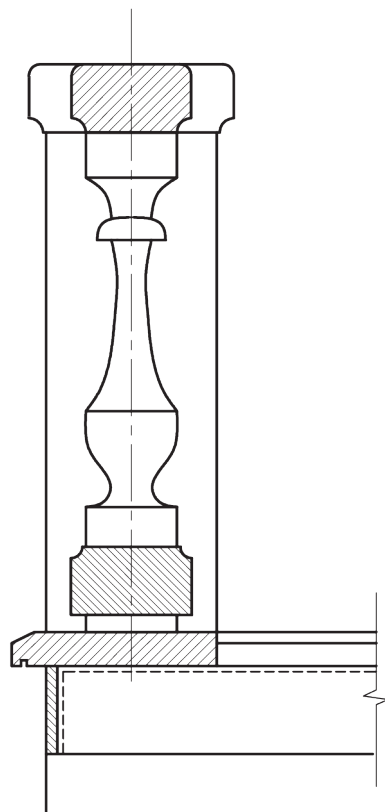
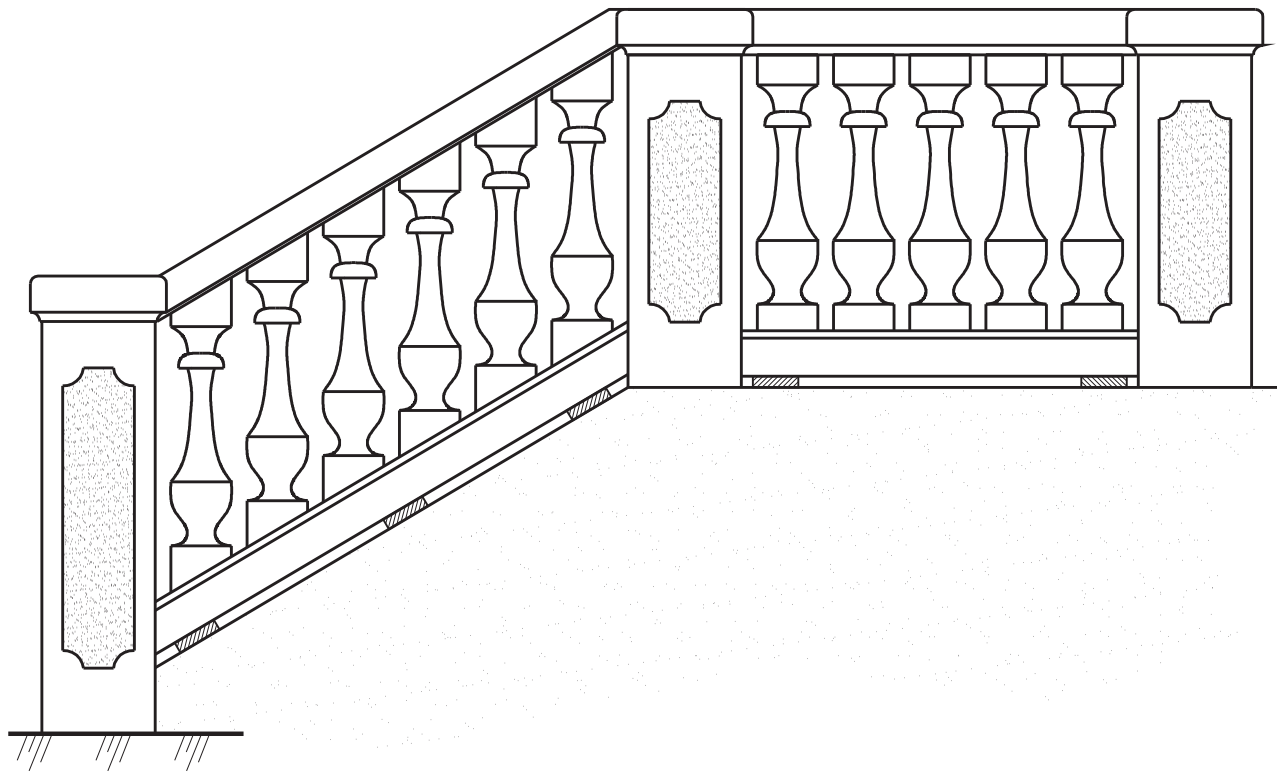

2.3. skirting board

a stone strip that is fixed to the lower side of the wall with thick mixture or glued with tiling mixtures or mastic to protect the floor from staining during use or cleaning.

Dimensions:

- common heights: 60; 80; 100 mm
- thicknesses: 10; 15; 20 mm

Base surface:

base surface must be clean and free from all residual substances that may distend or react on fixing mixtures (plaster, wood, insulation, etc).

Suggested reserves:

When installing the skirting board, allow for the thickness of the board + 5–10 mm for fixing mixture.

Joints:

- The joint between the skirting board and floor
- panels is filled with elastic joint mastic.
- joints: the width exceeds or is equal to 1 mm.
- joints are filled with joint mixtures.
- expansion and dividable joints are filled with elastic joint mastic



Rumene / Orgita dolomite

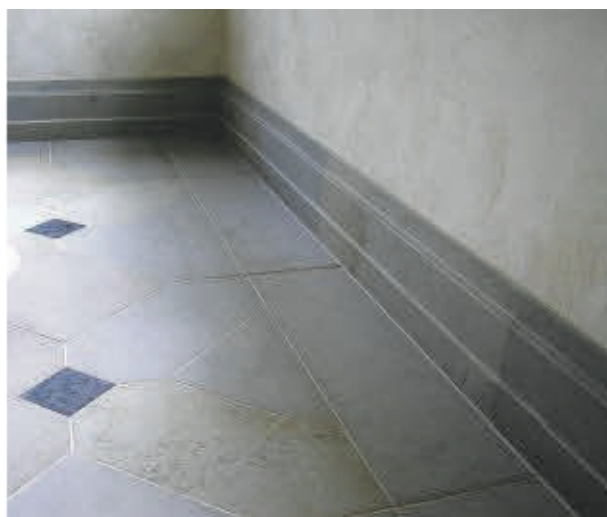

Rumene / Orgita dolomite

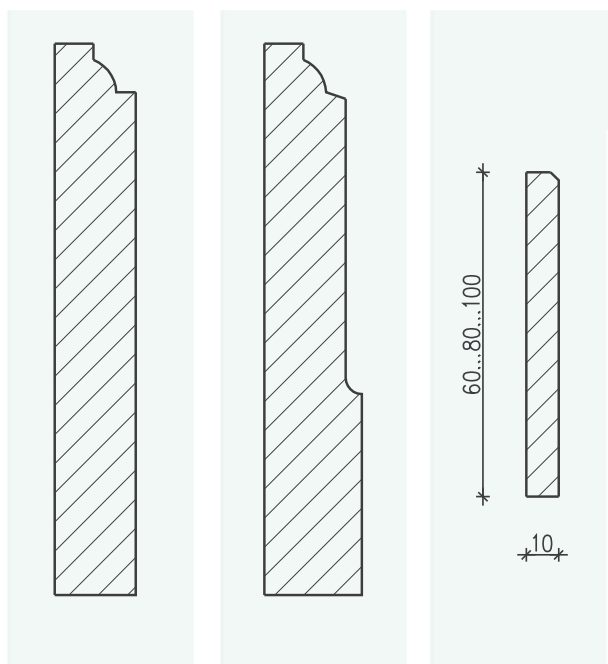

Rumene / Orgita dolomite



Tallinn / Kaarma dolomite ceiling

suspended ceilings from natural stone panels



2.4. suspended ceilings

It is possible to install suspended ceilings, either of different shapes or modulated, from natural stone panels to non-insulated or insulated ceilings.

Choice of materials:

- the chosen stone must correspond to the technical requirements depending on the location, in external conditions the stone must also correspond to the local weather conditions.
- the thickness of the stone (3–4 cm) is determined by the dimensions, function, density, and compression strength of the stone.

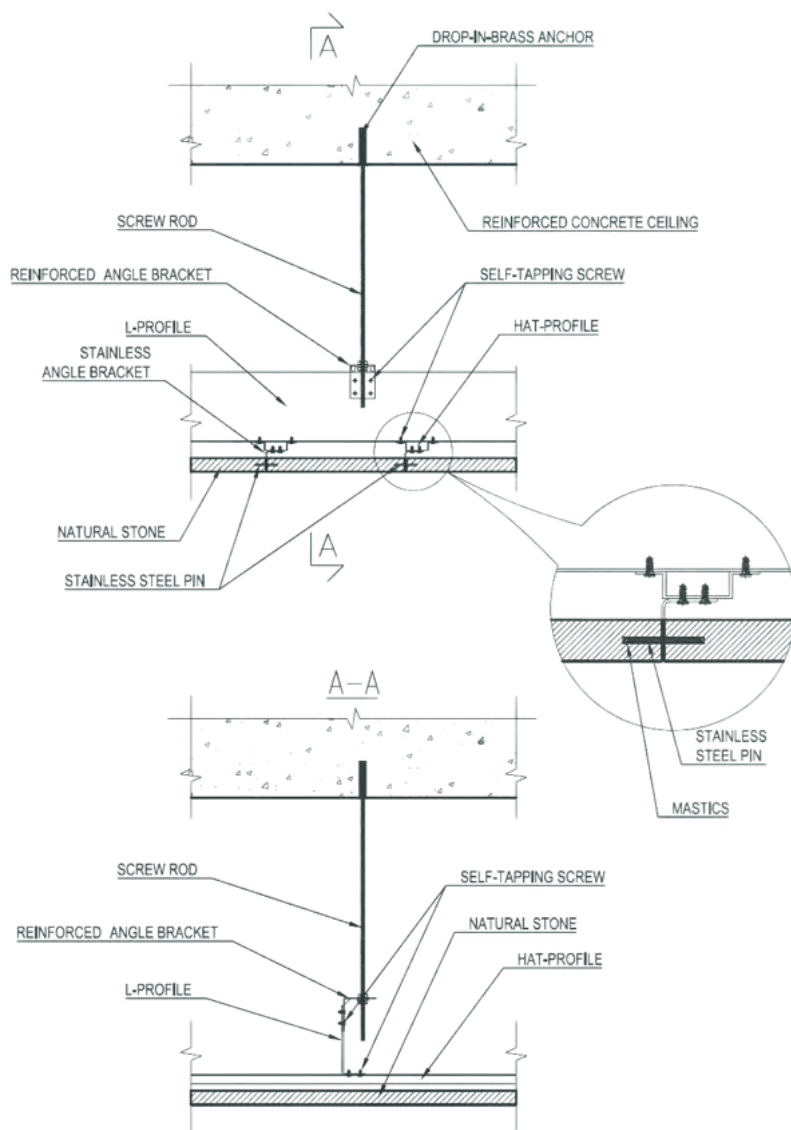

Installing to ceilings:

Plate anchor fixing:

Natural stone panels are attached to the anchors with stainless steel splines that are inserted in the holes drilled 10–20 cm away from the corners of the panel. The diameter of the hole must be 0.5–3 mm bigger than the diameter of the spline.

Installation holes must be drilled as follows:

- The axis of the hole must be in the centre of the panel thickness, and about $L/5$ away from the corners.
- The thickness of the remaining stone from the edge of the hole to the edge of the panel must be at least 10 mm in the case of a 3 cm panel.
- The depth of the hole must be at least 30 mm, and it should be 5 mm deeper than the end of the spline inserted in the stone.

Adjusting splines:

- splines can be adjusted in both directions when the hole of the spline is up to 10 mm deeper.
- before inserting the spline, the hole is filled with a special mixture or mastic

Joints:

They may be left open or filled with elastic mastic (for example urethane mastics, but not mastics that contain silicone oil, these will later leave thin, dark, oily marks around the edges of panels).



KUMU, Tallinn / Kaarma limestone

uses

Uses

Possible uses	Honed	Rough-ground	Polished	Antique	Split	Bush-hammered	Planed	Grooved
KAARMA	P				P	P	P	P
ORGITA	P				P	P	P	P
REVAL	P		P	P	P			P
SELGASE	P				P	P	P	P

Possible uses	Split-face outside	Facade coverings outside	Facade coverings inside	Rock face	Floorings and stairs inside	Floorings and stairs outside	Sawn and split inside	Sawn and split outside	Pavings and fences	Fireplaces
KAARMA	P	P	P	P		P	P	P	P	P
ORGITA	P	P	P	P	P	P	P	P		P
REVAL	P		P	P	P		P			P
SELGASE	P	P	P	P	P		P	P		P



Rumene / Orgita dolomite



Tallinn / Kaarma dolomite



Tallinn / Selgase dolomite



Tallinn / Kaarma dolomite

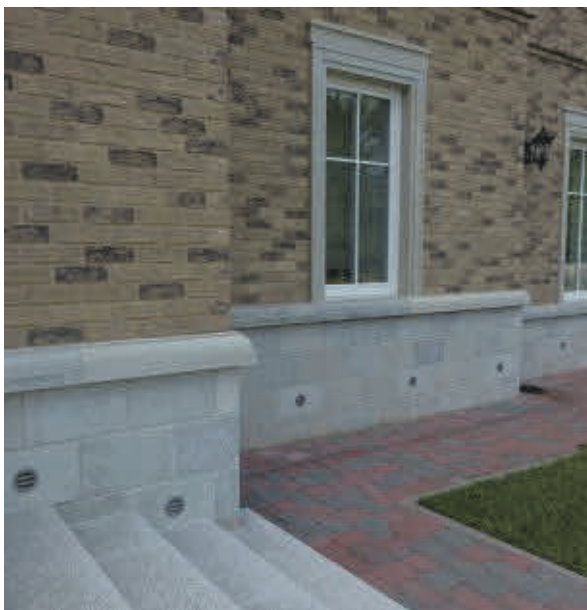

Tallinn / Kaarma dolomite



Tallinn / Kaarma dolomite



Tallinn / Reval limestone



Kuressaare / Kaarma dolomite



Kuressaare / Kaarma dolomite



Tallinn / Orgita dolomite



Tartu / Kaarma dolomite



Riga / Orgita dolomite





ORGITA



KAARMA



REVAL



SELGASE



Our stones

REVAL STONE

LIMESTONE FACTORIES OF ESTONIA

Kaarma honed



REVAL STONE

LIMESTONE FACTORIES OF ESTONIA

Orgita honed



REVAL STONE

LIMESTONE FACTORIES OF ESTONIA

Selgase honed



REVAL STONE

LIMESTONE FACTORIES OF ESTONIA

Reval honed



REVAL STONE

LIMESTONE FACTORIES OF ESTONIA

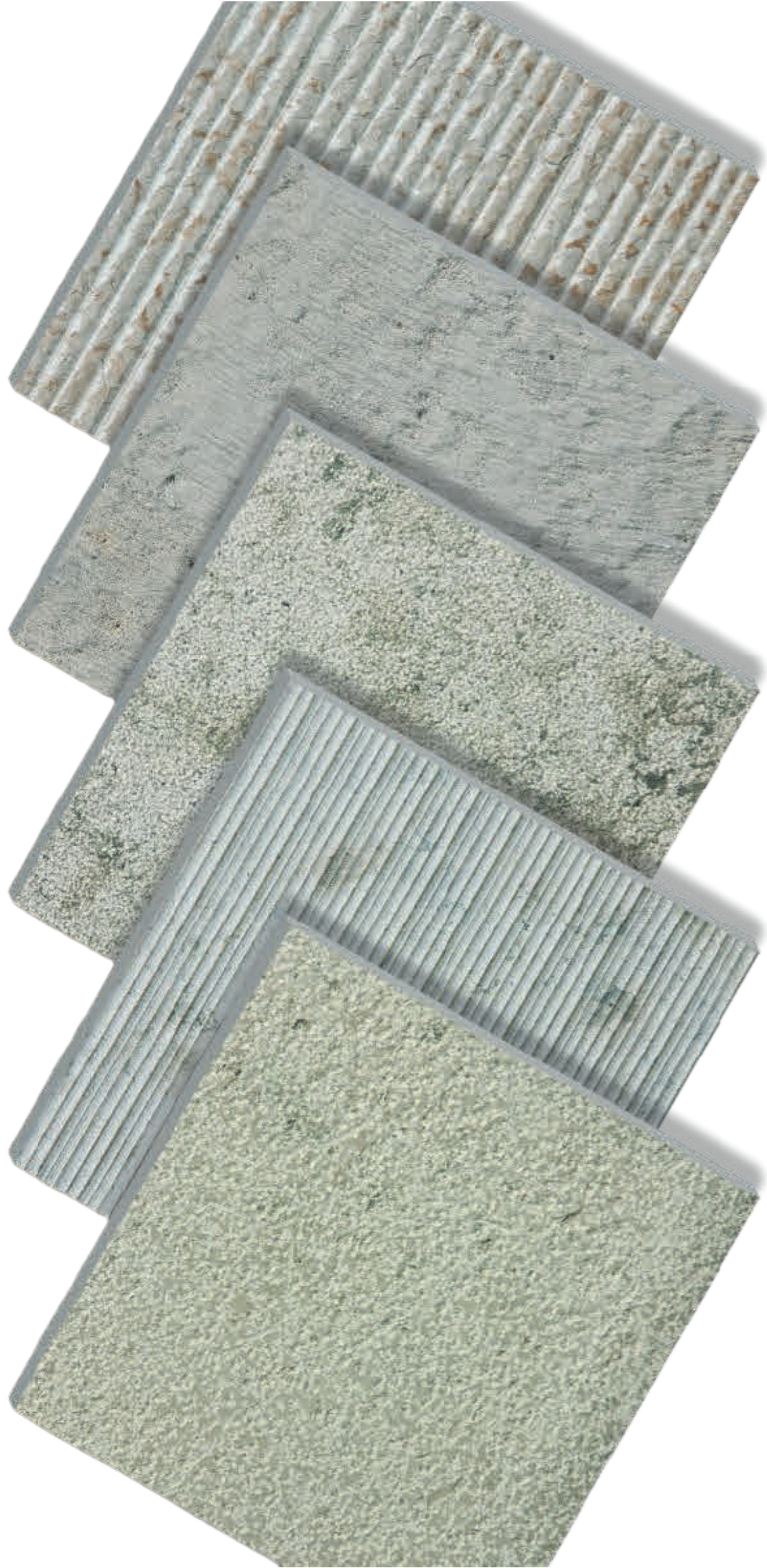

finishes

Orgita bush-hammered

Finished by hitting the stone with a bush-hammer (a special hammer with a grooved head comprised of 16 to 64 teeth) which leaves a rough but consistent grid texture of 1 or 3 mm deep.

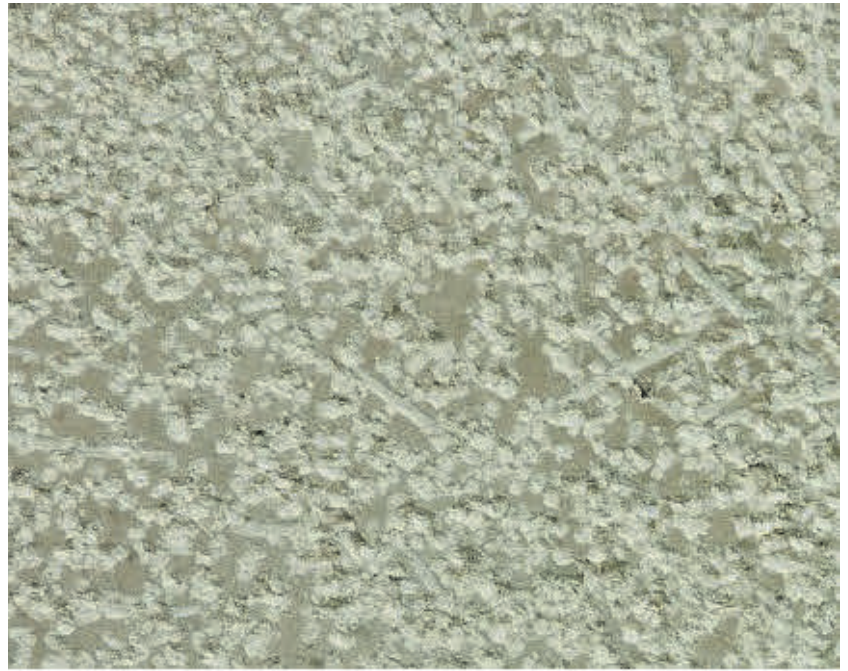

Reval bush-hammered

Finished by hitting the stone with a bush-hammer (a special hammer with a grooved head comprised of 16 to 64 teeth) which leaves a rough but consistent grid texture of 1 or 3 mm deep.



Selgase bush-hammered

Finished by hitting the stone with a bush-hammer (a special hammer with a grooved head comprised of 16 to 64 teeth) which leaves a rough but consistent grid texture of 1 or 3 mm deep.



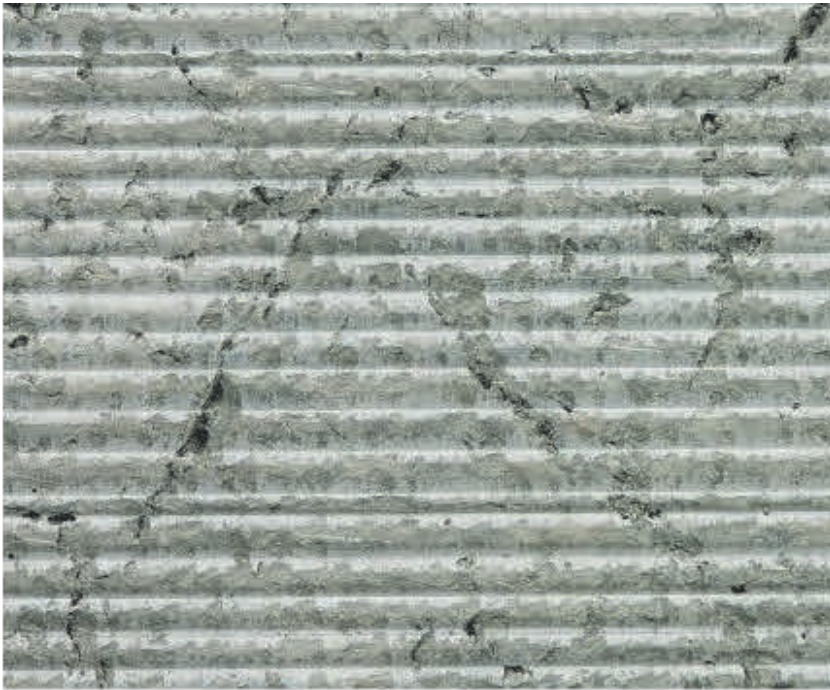

Kaarma planed

Flat finishing composed of fine parallel ribbings, 1 to 2 mm deep, between which there are ridges with a rough split texture.



Orgita planed

Flat finishing composed of fine parallel ribbings, 1 to 2 mm deep, between which there are ridges with a rough split texture.

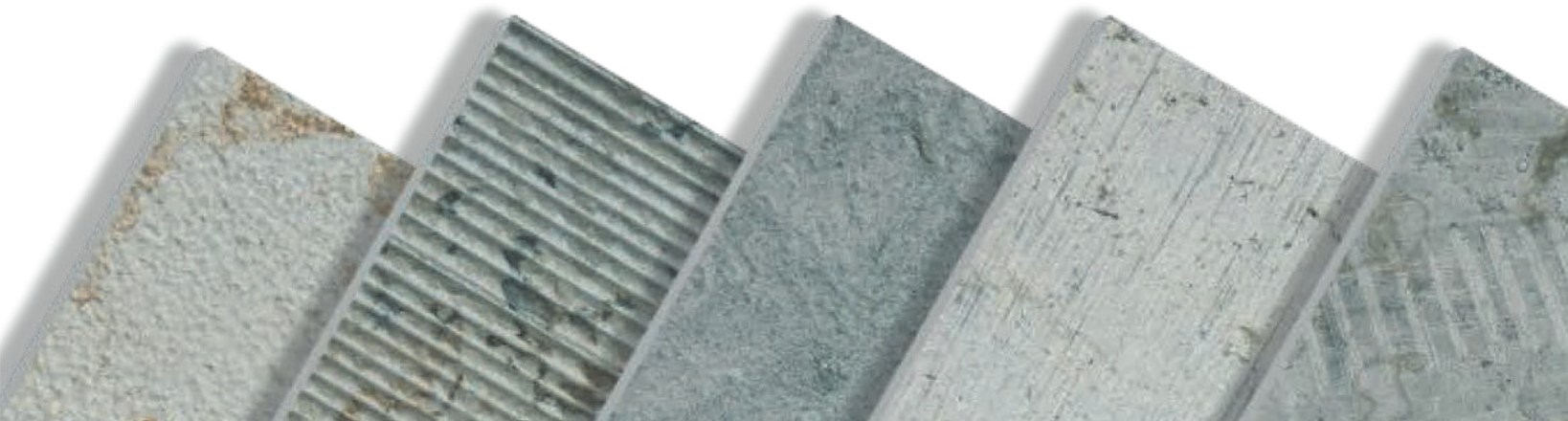

Kaarma sawn

Sawn surface that may have the stripes or curved tracks from cutting tools.



Kaarma honed & ribbed

A ribbed finish involves cutting the stone surface with parallel saw cuts at regular intervals, typically with a width step of 5 mm and with varying depths. This creates a distinctive, textured pattern of linear grooves that enhances the visual interest and provides a tactile surface.

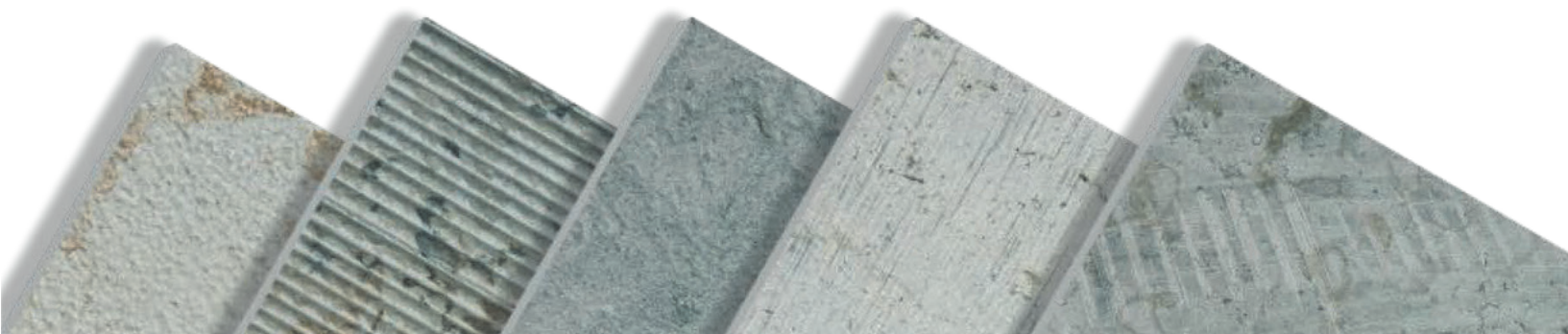



Selgase planed

Flat finishing composed of fine parallel ribbings, 1 to 2 mm deep, between which there are ridges with a rough split texture.



Reval antique

Antique surface looks worn. Usually the sawn surface is treated with abrasive brushes. Can be also sand-blasted and brushed or flamed and brushed. Generally silky rough surface.



Reval sawn

Sawn surface that may have the stripes or curved tracks from cutting tools.

Kaarma grooved

A grooved finish is created using multiple saw blades packed together to cut parallel grooves into the stone. This technique produces a series of uniform, narrow channels across the surface, resulting in a highly textured, ribbed appearance.



Orgita grooved

A grooved finish is created using multiple saw blades packed together to cut parallel grooves into the stone. This technique produces a series of uniform, narrow channels across the surface, resulting in a highly textured, ribbed appearance.



Reval grooved

A grooved finish is created using multiple saw blades packed together to cut parallel grooves into the stone. This technique produces a series of uniform, narrow channels across the surface, resulting in a highly textured, ribbed appearance.





Kaarma scratched

A scratched finish features fine, linear grooves etched into the surface. This texture provides a rustic, weathered look and enhances the stone's natural characteristics.



Orgita scratched

A scratched finish features fine, linear grooves etched into the surface. This texture provides a rustic, weathered look and enhances the stone's natural characteristics.



Reval scratched

A scratched finish features fine, linear grooves etched into the surface. This texture provides a rustic, weathered look and enhances the stone's natural characteristics.

Kaarma diamond honed

A diamond-honed finish, also known as a calibrated finish, is achieved by using diamond abrasives to grind the stone surface to a smooth, flat, and consistent level. This process is one step before full honing, leaving the stone with a matte, slightly textured appearance that enhances its natural color and pattern.



Orgita diamond honed

A diamond-honed finish, also known as a calibrated finish, is achieved by using diamond abrasives to grind the stone surface to a smooth, flat, and consistent level. This process is one step before full honing, leaving the stone with a matte, slightly textured appearance that enhances its natural color and pattern.



Reval diamond honed

A diamond-honed finish, also known as a calibrated finish, is achieved by using diamond abrasives to grind the stone surface to a smooth, flat, and consistent level. This process is one step before full honing, leaving the stone with a matte, slightly textured appearance that enhances its natural color and pattern.





split-face outside

Reval
split-face



Selgase
split-face



Kaarma
split-face





Selgase
yellow
split-face



Orgita
split-face



Reval
split-face

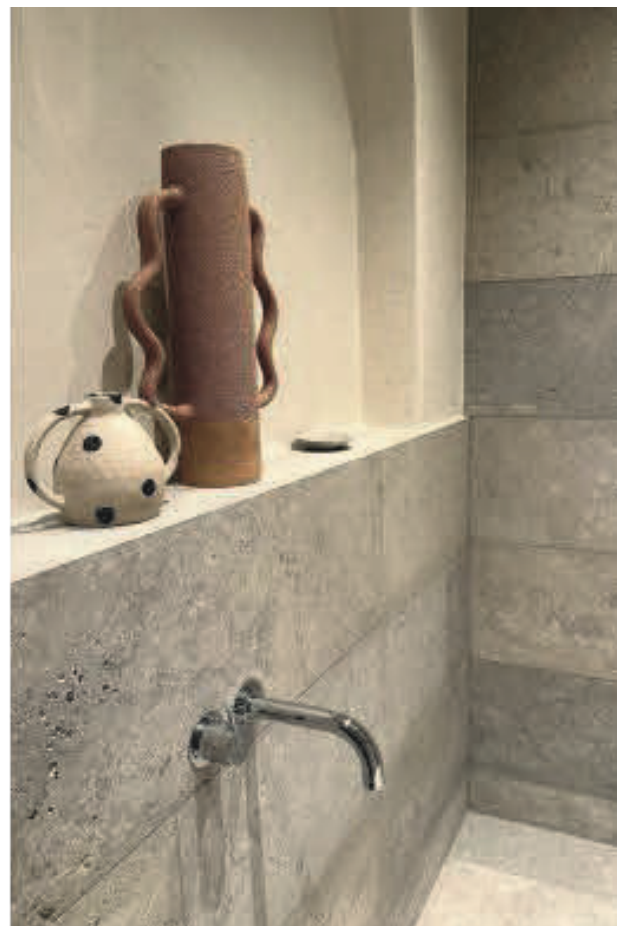

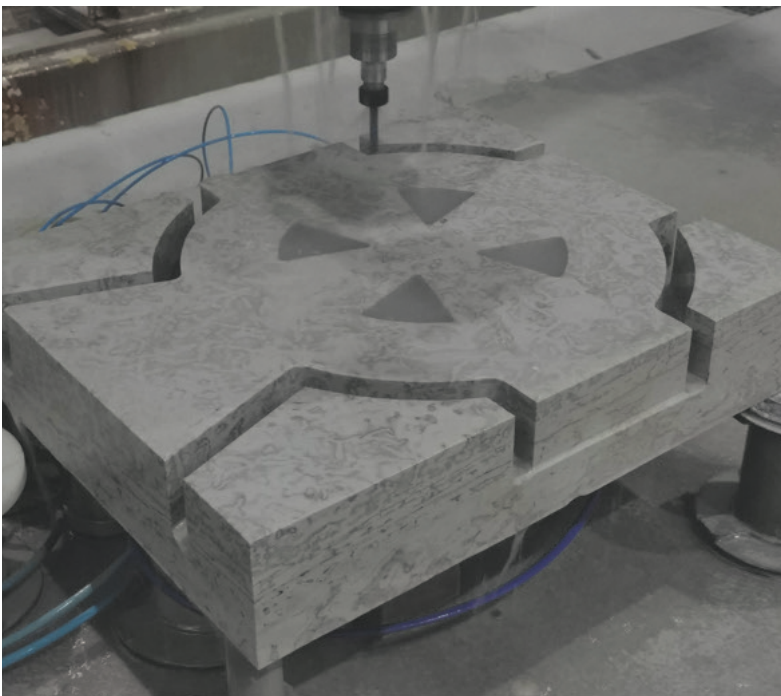



PINE EDGE VILLA